

# XAT - 2023

## XAVIER APTITUDE TEST-2023

XAT ID	
Candidate Name	
TC Name	

### Section : Verbal Ability & Logical Reasoning

#### Q.1 Read the following sentences carefully.

1. The boss accused her employee for stealing information.
2. The boss had better discuss the issue with the employee concerned.
3. The India of 2022 is very different from the India of 1947.
4. The government is committed to providing people with food.
5. He is good in playing the piano.

From the following, identify the option with **INCORRECT** sentences.

- Options
- A. 2, 3
  - B. 3, 4
  - C. 1, 2
  - D. 4, 5
  - E. 1, 5

Question ID : 4156997  
Status : Answered  
Chosen Option : E

#### Q.2 Read the following excerpt carefully.

In the future, hydrogen may form a significant part of our energy systems. Today it is mostly used in oil refineries and fertiliser but in the future hydrogen could power our cars, heat our homes, and fuel industry. A recent McKinsey study suggested that in less than 25 years, hydrogen could account for 18% of global energy consumption and reduce carbon dioxide emissions from current levels by some 6 gigatons....

Which of the following sentences will **MOST** logically complete the above excerpt?

- Options
- A. The impact of such a change in the energy system would be huge, potentially generating \$2,500 billion in revenue globally and creating more than 30 million jobs.
  - B. Despite the potential, 90% of the general population knew nothing about hydrogen technology.
  - C. Earlier, experts thought that hydrogen fuel would be too expensive.
  - D. Hydrogen can be made through reformation, electrolysis, or pyrolysis, comes labelled in different colours from simple green to more complicated turquoise, can be stored as a gas, cryogenic liquid, converted to ammonia or even borane and then finally made useful through a fuel cell, engine, or burner.
  - E. Germany unsuccessfully experimented with trains fuelled by hydrogen.

Question ID : 4156998  
Status : Answered  
Chosen Option : A

**Q.3 Which of the following sentences have the CORRECT usage of punctuation?**

- Options**
- A. Italy is famous for their composers and musicians; France, for their chefs and philosophers; Poland for their mathematicians and logicians.
  - B. Italy is famous for its composers and musicians. France for its chefs and philosophers. Poland for its mathematicians and logicians.
  - C. Italy is famous for its composers and musicians, France for its chefs and philosophers, Poland for its mathematicians and logicians.
  - D. Italy is famous, for their composers and musicians; France, for their chefs and philosophers; Poland for their mathematicians and logicians.
  - E. Italy is famous for its composers and musicians, France, for its chefs and philosophers, and Poland, for its mathematicians and logicians.

Question ID : 4156994

Status : Answered

Chosen Option : E

**Q.4 Read the following paragraph and answer the question that follows.**

**The fundamental laws that govern the smallest constituents of matter and energy, when applied to the Universe over long enough cosmic timescales, can explain everything that will ever emerge. This means that the formation of literally everything in our Universe, from atomic nuclei to atoms to simple molecules to complex molecules to life to intelligence to consciousness and beyond, can all be understood as something that emerges directly from the fundamental laws underpinning reality, with no additional laws and forces.**

**Which of the following can be BEST inferred from the paragraph above?**

- Options**
- A. All phenomena in the Universe fundamentally occur spontaneously.
  - B. Fundamental laws operating in the Universe and in an atom are the same.
  - C. Fundamental laws undergo a change from atom to the Universe.
  - D. Everything in the Universe fundamentally occurs randomly.
  - E. All phenomena in the Universe are fundamentally dependent on long cosmic timescales.

Question ID : 4156993

Status : Answered

Chosen Option : B

**Q.5 Arrange the following into a meaningful sequence:**

1. I'm not sure when I first became aware of the Singularity.
2. In the almost half century that I've immersed myself in computer and related technologies, I've sought to understand the meaning and purpose of the continual upheaval that I have witnessed at many levels.
3. Gradually, I've become aware of a transforming event looming in the first half of the twenty first century.
4. I'd have to say it was a progressive awakening.
5. Just as a black hole in space dramatically alters the patterns of matter and energy accelerating toward its event horizon, this impending Singularity in our future is increasingly transforming every institution and aspect of human life, from sexuality to spirituality.

- Options**
- A. 3,1,2,4,5
  - B. 1,3,4,5,2
  - C. 1,2,3,4,5
  - D. 4,1,2,3,5
  - E. 4,3,1,5,2

Question ID : 4156991

Status : Answered

Chosen Option : C

**Q.6** Read the following passage and answer the question that follows.

More people signed up for Harvard's online courses in a year, for example, than have attended the university in its 377 years of existence. In the same spirit, there are more unique visits each month to the WebMD network, a collection of health websites, than to all the doctors working in the United States. In the legal world, three times as many disagreements each year amongst eBay traders are resolved using 'online dispute resolution' than there are lawsuits filed in the entire US court system. On its sixth birthday, the Huffington Post had more unique monthly visitors than the website of the New York Times, which is almost 164 years of age. The British tax authorities use a fraud-detection system that holds more data than the British Library (which has copies of every book ever published in the UK). In 2014, the US tax authorities received electronic tax returns from almost 48 million people who had used online tax preparation software rather than a tax professional to help them. The architectural firm Gramazio & Kohler used a group of autonomous flying robots to assemble a structure out of 1500 bricks. The consulting firm Accenture has 750 hospital nurses on its staff, while Deloitte, founded as an audit practice 170 years ago, now has over 200,000 professionals and its own full-scale corporate university set in a 700,000-square-foot campus in Texas.

The author of the above paragraph is trying to conclude something by citing different pieces of evidence. What could the author be trying to prove?

- Options**
- A. What old firms can do to survive.
  - B. How professionals are getting replaced by technology
  - C. How new organizational forms are emerging
  - D. How old firms are dying.
  - E. How automation is taking away jobs traditionally done by humans.

Question ID : 4156999  
Status : Answered  
Chosen Option : C

**Q.7** Read the following sentences carefully.

1. The exam will begin from 2:00 p.m. on January 8th.
2. While entering into the college building, he saw the statue of Mahatma Gandhi.
3. The government has entered into a discussion with the local bodies for keeping the streets clean.
4. I will start my world tour from Sri Lanka.
5. Amitabh Bacchan is married with Jaya Bacchan
6. I have been working on this project for three weeks.

From the following, choose the option having all the CORRECT sentences.

- Options**
- A. 1, 3, 4
  - B. 4, 5, 6
  - C. 1, 2, 5
  - D. 3, 4, 6
  - E. 2, 3, 5

Question ID : 4156996  
Status : Answered  
Chosen Option : D

**Q.8** Arrange the following into a meaningful sequence:

1. Our knowledge about life developed over the centuries thanks to the many philosophers, physicists, chemists and biologists, who examined such complex matters according to their different points of view.
2. Out of this long history, I wish to quote here only one date, the year 1953.
3. In that year, Miller and Urey carried out their famous experiment about the primordial universal soup, whose foundations had already been expounded by the Russian chemist Alexandre Oparin in 1924.
4. From a mixture of five gases, methane, ammonia, carbon dioxide, hydrogen and water vapor, and an electric discharge as the source of energy, complex molecules were produced, including amino acids.

- Options**
- A. 1,2,3,4
  - B. 1,3,4,2
  - C. 2,3,1,4
  - D. 3,1,2,4
  - E. 1,4,2,3

Question ID : 4156992

Status : Answered

Chosen Option : A

**Q.9** Read the following passage and answer the question that follows.

As a generation, we are rethinking what we are to others. Our technological prowess has become a wireless lifeline for others. Some of us apply ourselves to innovation: hackathons and other forms of technological creativity. Our families look to us to know how to use technology both to waste time and to make meaning. Some of us set up Facetime for those denied face-to-face time. We show them it will be OK, that digital relationships are real relationships – though in fact we are not always sure. Which of the following, will be a most MEANINGFUL conclusion of the passage?

- Options**
- A. Technology is destroying families and communities
  - B. Change is the only constant in life, so people must embrace technology
  - C. Technology usage has changed social relations for this generation
  - D. The Pandemic has increased societal dependence on technology
  - E. Technological advancement helps society derive meaning from work

Question ID : 41569911

Status : Answered

Chosen Option : C

**Q.10** Fill up the blanks with appropriate words.

Oil painting did to appearance what capital did to social \_\_\_\_\_. It reduced everything to the \_\_\_\_\_ of objects. Everything became \_\_\_\_\_ because everything became a commodity. All reality was mechanically \_\_\_\_\_ by its materiality.

- Options**
- A. Justice, level, expensive, understood
  - B. Reality, randomness, saleable, located
  - C. Setup, understanding, useless, identified
  - D. Relations, equality, exchangeable, measured
  - E. Construction, minuteness, commercial, evaluated

Question ID : 4156995

Status : Answered

Chosen Option : D

**Q.11 Read the following statements.**

**The leave policy is bound to be unpopular either with the management or among workers. If the leave policy is unpopular with the management, it should be modified. We should adopt a new policy if it is unpopular with workers. If the above statements are true, which one of the following MUST also be true?**

- Options**
- A. We should attempt to popularize the leave policy among either the management or workers.
  - B. If the leave policy is popular among workers, then we should adopt a new policy.
  - C. We should modify the leave policy only if this will not reduce its popularity among workers.
  - D. If the leave policy is popular with the management, then we should adopt a new policy.
  - E. We should modify the leave policy if modification will not reduce its popularity with the management.

Question ID : 41569910

Status : Answered

Chosen Option : E

**Q.12 When facing various challenges, people in today's digital world heavily rely on private, online information-seeking behaviour. Individuals who experience depression will often attempt to understand their predicament and seek remedy by searching the Internet for depression-related information and treatment. A recent report says that there exists evidence of many searches comprising the word depression, during and just after the elections, in country Y. So, it can be concluded that the election is experienced by many people in country Y as a truly psychologically traumatizing event—and as such as being potentially depressionogenic.**

**Which of the following statements MOST seriously weakens the conclusion drawn in the passage?**

- Options**
- A. Per day sale of anti-depression drugs is constant across the years in country Y.
  - B. Election is a festival in some countries, people happily choose their leader by casting votes.
  - C. Depression-related advertisements are on the rise during and just after the election in country Y.
  - D. A survey in country Y shows that an election can cause a significant increase in the average level of depression.
  - E. Many people do not use the Internet in country X.

Question ID : 41569912

Status : Answered

Chosen Option : C

**Comprehension:**

**Read the following passage and answer the THREE questions that follow.**

Corporations continue to ignore the threat of global warming, probably because global warming is a hyper-object, very difficult to touch and feel. Because hyper-objects have much wider time-space boundaries than human beings, we tend to consider hyper-objects as given and non-existent. Therefore, it is very difficult to deal with hyper-objects as their common understanding is lacking. Some of us continue to believe that global warming is blown out of proportion-it is not a serious threat. Even those who understood hyper-objects have yet to figure out right response to them.

The lack of understanding and response from corporations to "climate change" is evident from the fact that most of businesses have remained largely human-centric. Some businesses have adopted green practices- voluntarily, or involuntary. These efforts attempt to reduce emissions through better energy efficiency. Though laudable, the efforts have failed to make any significant dent at the global level; the planet continues to get warmer. Moreover, most of the efforts are still in the sphere of "business as usual" and "what is good for us".

Business as usual, the current model of economic production and distribution is deeply flawed as it is based mainly on the capitalistic ethos of free-market legitimized through private property, competition, and unlimited consumption. The word "free" has come to mean that there are no constraints on individuals, and the word market has come to mean that buying and selling are the primary mechanisms, and everything is a transaction. Private property gives individuals/nations a chance to create legal rights to own more and more, subject to very little constraints. It is evident in income inequalities witnessed across the world. The very notion of ownership is control-oriented and human-centric that promotes unlimited extraction from environment, hyper-nationalism, and hyper-individualism. The extraction and exploitation of the environment has served our economic interests, and led to the growth and survival of businesses. However, it has also led to the destruction of environment. Global warming is the response of nature to human actions driven by businesses operating on the principles of surplus, predictability, control, hyper-rationality, linearity, and quantification. In other words, "business as usual" has yet to dance to the rhythm of nature.

**SubQuestion No : 13**

**Q.13 According to the passage, which of the following will be closest to the idea of hyper-object?**

- Options**
- A. How a technology company contributed to the development of a mobile phone technology.
  - B. How regular exercise makes our body healthy.
  - C. How temperature fluctuates because of seasons.
  - D. How hard work leads to better grades for students.
  - E. How the Earth, over centuries, takes less time to revolve around the Sun.

Question ID : 41569925

Status : Answered

Chosen Option : E

**Comprehension:**

**Read the following passage and answer the THREE questions that follow.**

Corporations continue to ignore the threat of global warming, probably because global warming is a hyper-object, very difficult to touch and feel. Because hyper-objects have much wider time-space boundaries than human beings, we tend to consider hyper-objects as given and non-existent. Therefore, it is very difficult to deal with hyper-objects as their common understanding is lacking. Some of us continue to believe that global warming is blown out of proportion-it is not a serious threat. Even those who understood hyper-objects have yet to figure out right response to them.

The lack of understanding and response from corporations to "climate change" is evident from the fact that most of businesses have remained largely human-centric. Some businesses have adopted green practices- voluntarily, or involuntary. These efforts attempt to reduce emissions through better energy efficiency. Though laudable, the efforts have failed to make any significant dent at the global level; the planet continues to get warmer. Moreover, most of the efforts are still in the sphere of "business as usual" and "what is good for us".

Business as usual, the current model of economic production and distribution is deeply flawed as it is based mainly on the capitalistic ethos of free-market legitimized through private property, competition, and unlimited consumption. The word "free" has come to mean that there are no constraints on individuals, and the word market has come to mean that buying and selling are the primary mechanisms, and everything is a transaction. Private property gives individuals/nations a chance to create legal rights to own more and more, subject to very little constraints. It is evident in income inequalities witnessed across the world. The very notion of ownership is control-oriented and human-centric that promotes unlimited extraction from environment, hyper-nationalism, and hyper-individualism. The extraction and exploitation of the environment has served our economic interests, and led to the growth and survival of businesses. However, it has also led to the destruction of environment. Global warming is the response of nature to human actions driven by businesses operating on the principles of surplus, predictability, control, hyper-rationality, linearity, and quantification. In other words, "business as usual" has yet to dance to the rhythm of nature.

**SubQuestion No : 14**

**Q.14 Based on the passage, which of the following is NOT an example of human-centric statement?**

- Options**
- A. We should not cut trees as it causes excessive floods, destroying crops and human habitats.
  - B. We should respect nature for its inherent intelligence.
  - C. We should use natural resources for economic growth.
  - D. We should preserve nature for our future generations.
  - E. We should plant trees as they provide us with Oxygen.

Question ID : 41569926

Status : Answered

Chosen Option : B

**Comprehension:**

**Read the following passage and answer the THREE questions that follow.**

Corporations continue to ignore the threat of global warming, probably because global warming is a hyper-object, very difficult to touch and feel. Because hyper-objects have much wider time-space boundaries than human beings, we tend to consider hyper-objects as given and non-existent. Therefore, it is very difficult to deal with hyper-objects as their common understanding is lacking. Some of us continue to believe that global warming is blown out of proportion-it is not a serious threat. Even those who understood hyper-objects have yet to figure out right response to them.

The lack of understanding and response from corporations to "climate change" is evident from the fact that most of businesses have remained largely human-centric. Some businesses have adopted green practices- voluntarily, or involuntary. These efforts attempt to reduce emissions through better energy efficiency. Though laudable, the efforts have failed to make any significant dent at the global level; the planet continues to get warmer. Moreover, most of the efforts are still in the sphere of "business as usual" and "what is good for us".

Business as usual, the current model of economic production and distribution is deeply flawed as it is based mainly on the capitalistic ethos of free-market legitimized through private property, competition, and unlimited consumption. The word "free" has come to mean that there are no constraints on individuals, and the word market has come to mean that buying and selling are the primary mechanisms, and everything is a transaction. Private property gives individuals/nations a chance to create legal rights to own more and more, subject to very little constraints. It is evident in income inequalities witnessed across the world. The very notion of ownership is control-oriented and human-centric that promotes unlimited extraction from environment, hyper-nationalism, and hyper-individualism. The extraction and exploitation of the environment has served our economic interests, and led to the growth and survival of businesses. However, it has also led to the destruction of environment. Global warming is the response of nature to human actions driven by businesses operating on the principles of surplus, predictability, control, hyper-rationality, linearity, and quantification. In other words, "business as usual" has yet to dance to the rhythm of nature.

**SubQuestion No : 15**

**Q.15 Which of the following statement(s) is NOT in consonance with the author's views, as expressed in the passage?**

- 1. Patents should be respected.**
- 2. Trading of shares on the free stock markets should be promoted.**
- 3. Building a beautiful resort on a hilltop.**

**Options** A. 1 & 2 only

B. 1 & 3 only

C. 1, 2 & 3

D. 2 & 3 only

E. 3 only

Question ID : 41569927

Status : Not Answered

Chosen Option : --



**Comprehension:**

**Read the following passage and answer the THREE questions that follow.**

It is harder and harder to make sense of life. Everything is changing, all the time, at a faster and faster pace. Our civilization is struggling to keep up with exponential technology and disruptive change. Our age-old institutions, politics, economics, ethics, religion and laws, even our environment, are so fundamentally challenged, that we risk collapse. Our stories have gotten so divorced from reality, so divisive, so inflexible and so inept to adapt to and explain our present, let alone guide us towards a better future, that we often feel like helpless passengers on a Titanic spaceship Earth. No wonder Aristotle observed that "When the storytelling goes bad in a society, the result is decadence."

But why is this the case? And, perhaps more importantly, how is it that bad storytelling can keep, if not bring, a whole society down? Is that not simply overstating the power of story? Literary theorist Kenneth Burke famously noted: "Stories are equipment for human living. We need storytelling in order to make certain sense out of life." If that is true then our equipment for living has gone obsolete. And unless we upgrade it we are going to go obsolete too.

It was this process that Fred Polak had in mind in 1961 while observing:

Any student of the rise and fall of cultures cannot fail to be impressed by the role played in this historical succession by the image of the future. The rise and fall of images precede or accompany the rise and fall of cultures. As long as a society's image is positive and flourishing, the flower of culture is in full bloom. Once the image begins to decay and lose its vitality, however, the culture does not long survive.

That is why we desperately need a new story. A story that will not only help us make sense of the world today but also unite us as a species of human beings. A story that will motivate us to stop bickering and resolve our common problems. A story that will inspire us to achieve our common goals and guide us towards a better future for all sentient beings on our planet.

We have to rewrite the human story. Because the old stories that brought us thus far are no longer useful. They've lost their vision and grandeur. They've become petty and short-sighted. They're stuck in a past that never was at the expense of a future that can be. They divide us and keep us bickering while our civilization is facing unprecedented diversity and depth of existential challenges. Those stories are not simply our history. They are now our chains. And unless we break them, they will be our death sentence.

So, it is worth exploring if or how new stories, good stories can bring us up.

The human story that brought us into the 21st century was written and rewritten several times. The latest major update was perhaps during the industrial revolution. It is time to rewrite it again. We need a new story. A brave story. An unreasonable story. A story that can inspire, unite and motivate us to break free from the past and create the best possible future.

**SubQuestion No : 16**

**Q.16 According to the passage, which of the following is NOT associated with bad storytelling in a society?**

**Options** A. It is inclusive.

B. It cannot stop bickering.

C. They were written before 21st Century.

D. It's inability to create a future image that is positive and flourishing.

E. Its ability to create a compelling goal for some sections.

Question ID : 41569929

Status : Answered

Chosen Option : A

**Comprehension:**

**Read the following passage and answer the THREE questions that follow.**

It is harder and harder to make sense of life. Everything is changing, all the time, at a faster and faster pace. Our civilization is struggling to keep up with exponential technology and disruptive change. Our age-old institutions, politics, economics, ethics, religion and laws, even our environment, are so fundamentally challenged, that we risk collapse. Our stories have gotten so divorced from reality, so divisive, so inflexible and so inept to adapt to and explain our present, let alone guide us towards a better future, that we often feel like helpless passengers on a Titanic spaceship Earth. No wonder Aristotle observed that "When the storytelling goes bad in a society, the result is decadence."

But why is this the case? And, perhaps more importantly, how is it that bad storytelling can keep, if not bring, a whole society down? Is that not simply overstating the power of story? Literary theorist Kenneth Burke famously noted: "Stories are equipment for human living. We need storytelling in order to make certain sense out of life." If that is true then our equipment for living has gone obsolete. And unless we upgrade it we are going to go obsolete too.

It was this process that Fred Polak had in mind in 1961 while observing:

Any student of the rise and fall of cultures cannot fail to be impressed by the role played in this historical succession by the image of the future. The rise and fall of images precede or accompany the rise and fall of cultures. As long as a society's image is positive and flourishing, the flower of culture is in full bloom. Once the image begins to decay and lose its vitality, however, the culture does not long survive.

That is why we desperately need a new story. A story that will not only help us make sense of the world today but also unite us as a species of human beings. A story that will motivate us to stop bickering and resolve our common problems. A story that will inspire us to achieve our common goals and guide us towards a better future for all sentient beings on our planet.

We have to rewrite the human story. Because the old stories that brought us thus far are no longer useful. They've lost their vision and grandeur. They've become petty and short-sighted. They're stuck in a past that never was at the expense of a future that can be. They divide us and keep us bickering while our civilization is facing unprecedented diversity and depth of existential challenges. Those stories are not simply our history. They are now our chains. And unless we break them, they will be our death sentence.

So, it is worth exploring if or how new stories, good stories can bring us up.

The human story that brought us into the 21st century was written and rewritten several times. The latest major update was perhaps during the industrial revolution. It is time to rewrite it again. We need a new story. A brave story. An unreasonable story. A story that can inspire, unite and motivate us to break free from the past and create the best possible future.

**SubQuestion No : 17**

**Q.17 Which of the following options BEST captures the essence of a GOOD STORY?**

- Options**
- A. Compared to other nations, our nation has played a special role in progress of humanity.
  - B. Life is full of sorrows and only death can provide a solution.
  - C. India has a glorious past, it had 25% share of global economy before arrival of the British
  - D. Everyone and I are a part of the universe.
  - E. Laying of railways led to economic and industrial development of India.

Question ID : 41569930

Status : Answered

Chosen Option : D

**Comprehension:**

**Read the following passage and answer the THREE questions that follow.**

It is harder and harder to make sense of life. Everything is changing, all the time, at a faster and faster pace. Our civilization is struggling to keep up with exponential technology and disruptive change. Our age-old institutions, politics, economics, ethics, religion and laws, even our environment, are so fundamentally challenged, that we risk collapse. Our stories have gotten so divorced from reality, so divisive, so inflexible and so inept to adapt to and explain our present, let alone guide us towards a better future, that we often feel like helpless passengers on a Titanic spaceship Earth. No wonder Aristotle observed that "When the storytelling goes bad in a society, the result is decadence."

But why is this the case? And, perhaps more importantly, how is it that bad storytelling can keep, if not bring, a whole society down? Is that not simply overstating the power of story? Literary theorist Kenneth Burke famously noted: "Stories are equipment for human living. We need storytelling in order to make certain sense out of life." If that is true then our equipment for living has gone obsolete. And unless we upgrade it we are going to go obsolete too.

It was this process that Fred Polak had in mind in 1961 while observing:

Any student of the rise and fall of cultures cannot fail to be impressed by the role played in this historical succession by the image of the future. The rise and fall of images precede or accompany the rise and fall of cultures. As long as a society's image is positive and flourishing, the flower of culture is in full bloom. Once the image begins to decay and lose its vitality, however, the culture does not long survive.

That is why we desperately need a new story. A story that will not only help us make sense of the world today but also unite us as a species of human beings. A story that will motivate us to stop bickering and resolve our common problems. A story that will inspire us to achieve our common goals and guide us towards a better future for all sentient beings on our planet.

We have to rewrite the human story. Because the old stories that brought us thus far are no longer useful. They've lost their vision and grandeur. They've become petty and short-sighted. They're stuck in a past that never was at the expense of a future that can be. They divide us and keep us bickering while our civilization is facing unprecedented diversity and depth of existential challenges. Those stories are not simply our history. They are now our chains. And unless we break them, they will be our death sentence.

So, it is worth exploring if or how new stories, good stories can bring us up.

The human story that brought us into the 21st century was written and rewritten several times. The latest major update was perhaps during the industrial revolution. It is time to rewrite it again. We need a new story. A brave story. An unreasonable story. A story that can inspire, unite and motivate us to break free from the past and create the best possible future.

**SubQuestion No : 18**

**Q.18 Read the following statements:**

- 1. A story without connections and coherence.**
- 2. A story that talks about recreating the past glory.**
- 3. A story may not be factually true.**
- 4. A story that is meaningful and compelling for humanity**

**Which of the above statements can be ASSOCIATED with the meaning of "unreasonable story", as used in the passage?**

**Options** A. 1&2

B. 2&4

C. 1&3

D. 3&4

E. 2&3

Question ID : 41569931

Status : Answered

Chosen Option : D

**Comprehension:**

**Read the poem and answer the TWO questions that follow.**

The slow person you left behind when, finally,  
you mastered the world, and scaled the heights you now command,  
where is he while you  
walked around the shaved lawn in your plus fours,  
organizing with an electric clipboard  
your big push to tomorrow?

Oh, I have come across him, yes, I have, more than once,  
coaxing his battered grocery cart down the freeway meridian,  
Others see in you sundry mythic types distinguished  
not just in themselves but by the stories  
we put in with beginnings, ends, surprises:  
the baby Oedipus on the hillside with his broken feet  
or the dog whose barking saves the grandmother  
flailing in the millpond beyond the weir,  
dragged down by her woolen skirt.

He doesn't see you as a story, though.

He feels you as his atmosphere. When your sun shines,  
he chortles. When your barometric pressure drops  
and the thunder heads gather,  
he huddles under the overpass and writes me long letters with  
the study little pencil he steals from the public library.  
He asks me to look out for you.

**SubQuestion No : 19**

**Q.19 Which of the following BEST captures the theme of the poem?**

- Options**
- A. The poem is analysing a person's past and present
  - B. The poem is meaninglessly brooding over the past
  - C. The poem is examining a loss of trust between old friends
  - D. The poem is celebrating success and moaning losses
  - E. The poem is exploring the lives of the rich and the poor

Question ID : 41569914  
Status : Answered  
Chosen Option : A

**Comprehension:**

**Read the poem and answer the TWO questions that follow.**

The slow person you left behind when, finally,  
you mastered the world, and scaled the heights you now command,  
where is he while you  
walked around the shaved lawn in your plus fours,  
organizing with an electric clipboard  
your big push to tomorrow?

Oh, I have come across him, yes, I have, more than once,  
coaxing his battered grocery cart down the freeway meridian,  
Others see in you sundry mythic types distinguished  
not just in themselves but by the stories

we put in with beginnings, ends, surprises:  
the baby Oedipus on the hillside with his broken feet  
or the dog whose barking saves the grandmother  
flailing in the millpond beyond the weir,  
dragged down by her woolen skirt.

He doesn't see you as a story, though.

He feels you as his atmosphere. When your sun shines,  
he chortles. When your barometric pressure drops  
and the thunder heads gather,  
he huddles under the overpass and writes me long letters with  
the study little pencil he steals from the public library.  
He asks me to look out for you.

**SubQuestion No : 20**

**Q.20 Which of the following statements BEST interprets the lines "He doesn't see you as a story, though/He feels you as his atmosphere"?**

- Options**
- A. You are haunted by your past
  - B. You are not a narrative of the past
  - C. You are an extension of the past
  - D. You are larger than life
  - E. Your present subsumes your past

Question ID : **41569915**

Status : **Not Answered**

Chosen Option : --

**Comprehension:**

**Read the following passage and answer the THREE questions that follow.**

Interpretation in our own time, however, is even more complex. For the contemporary zeal for the project of interpretation is often prompted not by piety toward the troublesome text (which may conceal an aggression), but by an open aggressiveness, an overt contempt for appearances. The old style of interpretation was insistent, but respectful; it erected another meaning on top of the literal one. The modern style of interpretation excavates, and as it excavates, destroys; it digs "behind" the text, to find a sub-text which is the true one. The most celebrated and influential modern doctrines, those of Marx and Freud, actually amount to elaborate systems of hermeneutics, aggressive and impious theories of interpretation. All observable phenomena are bracketed, in Freud's phrase, as manifest content. This manifest content must be probed and pushed aside to find the true meaning—the latent content beneath. For Marx, social events like revolutions and wars; for Freud, the events of individual lives (like neurotic symptoms and slips of the tongue) as well as texts (like a dream or a work of art)—all are treated as occasions for interpretation. According to Marx and Freud, these events only seem to be intelligible. Actually, they have no meaning without interpretation. To understand is to interpret. And to interpret is to restate the phenomenon, in effect to find an equivalent for it.

Thus, interpretation is not (as most people assume) an absolute value, a gesture of mind situated in some timeless realm of capabilities. Interpretation must itself be evaluated, within a historical view of human consciousness. In some cultural contexts, interpretation is a liberating act. It is a means of revising, of transvaluing, of escaping the dead past. In other cultural contexts, it is reactionary, impertinent, cowardly and stifling.

**SubQuestion No : 21**

**Q.21 What does the author mean by "Thus, interpretation is not...a gesture of mind situated in some timeless realm of capabilities?"**

- Options**
- A. Interpretation is an act of mind which is situated in a changeless domain.
  - B. Interpretation is about erecting another meaning on top of the literal one.
  - C. Interpretation is being evaluative of the meaning created by an authority.
  - D. Interpretation is about revisiting and reinventing meanings.
  - E. Interpretation is act of understanding, developed by timeless experts.

Question ID : **41569921**  
Status : **Answered**  
Chosen Option : **D**

**Comprehension:**

**Read the following passage and answer the THREE questions that follow.**

Interpretation in our own time, however, is even more complex. For the contemporary zeal for the project of interpretation is often prompted not by piety toward the troublesome text (which may conceal an aggression), but by an open aggressiveness, an overt contempt for appearances. The old style of interpretation was insistent, but respectful; it erected another meaning on top of the literal one. The modern style of interpretation excavates, and as it excavates, destroys; it digs "behind" the text, to find a sub-text which is the true one. The most celebrated and influential modern doctrines, those of Marx and Freud, actually amount to elaborate systems of hermeneutics, aggressive and impious theories of interpretation. All observable phenomena are bracketed, in Freud's phrase, as manifest content. This manifest content must be probed and pushed aside to find the true meaning—the latent content beneath. For Marx, social events like revolutions and wars; for Freud, the events of individual lives (like neurotic symptoms and slips of the tongue) as well as texts (like a dream or a work of art)—all are treated as occasions for interpretation. According to Marx and Freud, these events only seem to be intelligible. Actually, they have no meaning without interpretation. To understand is to interpret. And to interpret is to restate the phenomenon, in effect to find an equivalent for it.

Thus, interpretation is not (as most people assume) an absolute value, a gesture of mind situated in some timeless realm of capabilities. Interpretation must itself be evaluated, within a historical view of human consciousness. In some cultural contexts, interpretation is a liberating act. It is a means of revising, of transvaluing, of escaping the dead past. In other cultural contexts, it is reactionary, impertinent, cowardly and stifling.

**SubQuestion No : 22**

**Q.22 According to the passage, which of the following is NOT an act of interpretation?**

- Options**
- A. Finding underlying causes of a social evil described in a book
  - B. Critical appreciation of a literary text
  - C. Labelling a text as blasphemous
  - D. Investigating class-conflict in Charles Dicken's novels
  - E. Searching for underlying themes in a historical document

Question ID : **41569922**  
Status : **Answered**  
Chosen Option : **A**

**Comprehension:**

**Read the following passage and answer the THREE questions that follow.**

Interpretation in our own time, however, is even more complex. For the contemporary zeal for the project of interpretation is often prompted not by piety toward the troublesome text (which may conceal an aggression), but by an open aggressiveness, an overt contempt for appearances. The old style of interpretation was insistent, but respectful; it erected another meaning on top of the literal one. The modern style of interpretation excavates, and as it excavates, destroys; it digs "behind" the text, to find a sub-text which is the true one. The most celebrated and influential modern doctrines, those of Marx and Freud, actually amount to elaborate systems of hermeneutics, aggressive and impious theories of interpretation. All observable phenomena are bracketed, in Freud's phrase, as manifest content. This manifest content must be probed and pushed aside to find the true meaning—the latent content beneath. For Marx, social events like revolutions and wars; for Freud, the events of individual lives (like neurotic symptoms and slips of the tongue) as well as texts (like a dream or a work of art)—all are treated as occasions for interpretation. According to Marx and Freud, these events only seem to be intelligible. Actually, they have no meaning without interpretation. To understand is to interpret. And to interpret is to restate the phenomenon, in effect to find an equivalent for it.

Thus, interpretation is not (as most people assume) an absolute value, a gesture of mind situated in some timeless realm of capabilities. Interpretation must itself be evaluated, within a historical view of human consciousness. In some cultural contexts, interpretation is a liberating act. It is a means of revising, of transvaluing, of escaping the dead past. In other cultural contexts, it is reactionary, impertinent, cowardly and stifling.

**SubQuestion No : 23**

**Q.23 Which of the following BEST differentiates manifest content from the latent content?**

- Options**
- A. Manifest content is a superset whereas latent content is a subset
  - B. Manifest content is natural whereas latent content is cultural
  - C. Manifest content is obscure whereas latent content is lucid
  - D. Manifest content is loaded whereas latent content is elusive
  - E. Manifest content is apparent whereas latent content is hidden

Question ID : 41569923

Status : Answered

Chosen Option : E



**Comprehension:**

**Read the following passage and answer the THREE questions that follow.**

Socrates believed that akrasia (meaning procrastination) was, strictly speaking, impossible, since we could not want what is bad for us; if we act against our own interests, it must be because we don't know what's right. Loewenstein, similarly, is inclined to see the procrastinator as led astray by the "visceral" rewards of the present. As the nineteenth-century Scottish economist John Rae put it, "The prospects of future good, which future years may hold on us, seem at such a moment dull and dubious, and are apt to be slighted, for objects on which the daylight is falling strongly, and showing us in all their freshness just within our grasp." Loewenstein also suggests that our memory for the intensity of visceral rewards is deficient: when we put off preparing for that meeting by telling ourselves that we'll do it tomorrow, we fail to take into account that tomorrow the temptation to put off work will be just as strong.

Ignorance might also affect procrastination through what the social scientist Jon Elster calls "the planning fallacy." Elster thinks that people underestimate the time "it will take them to complete a given task, partly because they fail to take account of how long it has taken them to complete similar projects in the past and partly because they rely on smooth scenarios in which accidents or unforeseen problems never occur."

**SubQuestion No : 24**

**Q.24 According to the passage, in regard to time, which of the following statements gives the BEST reason for procrastination?**

- Options**
- A. Time is not taken into account
  - B. Time is taken as linear in the task
  - C. Time is not planned according to the task
  - D. Time is estimated according to the new task
  - E. Time is underestimated for a particular task

Question ID : 41569917  
Status : Answered  
Chosen Option : E

**Comprehension:**

**Read the following passage and answer the THREE questions that follow.**

Socrates believed that akrasia (meaning procrastination) was, strictly speaking, impossible, since we could not want what is bad for us; if we act against our own interests, it must be because we don't know what's right. Loewenstein, similarly, is inclined to see the procrastinator as led astray by the "visceral" rewards of the present. As the nineteenth-century Scottish economist John Rae put it, "The prospects of future good, which future years may hold on us, seem at such a moment dull and dubious, and are apt to be slighted, for objects on which the daylight is falling strongly, and showing us in all their freshness just within our grasp." Loewenstein also suggests that our memory for the intensity of visceral rewards is deficient: when we put off preparing for that meeting by telling ourselves that we'll do it tomorrow, we fail to take into account that tomorrow the temptation to put off work will be just as strong.

Ignorance might also affect procrastination through what the social scientist Jon Elster calls "the planning fallacy." Elster thinks that people underestimate the time "it will take them to complete a given task, partly because they fail to take account of how long it has taken them to complete similar projects in the past and partly because they rely on smooth scenarios in which accidents or unforeseen problems never occur."

**SubQuestion No : 25**

**Q.25 Which of the following statements can be BEST inferred from the passage about procrastination?**

- Options**
- A. It is an irrational delay of task despite potentially negative consequences.
  - B. It is a success of self-regulation and planning.
  - C. It is an act against our own interests because of our ignorance.
  - D. It is a mistake that happens due to myopic vision and linear thinking.
  - E. It is a tendency of postponing the present work to the future.

Question ID : 41569918

Status : Answered

Chosen Option : D

**Comprehension:**

**Read the following passage and answer the THREE questions that follow.**

Socrates believed that akrasia (meaning procrastination) was, strictly speaking, impossible, since we could not want what is bad for us; if we act against our own interests, it must be because we don't know what's right. Loewenstein, similarly, is inclined to see the procrastinator as led astray by the "visceral" rewards of the present. As the nineteenth-century Scottish economist John Rae put it, "The prospects of future good, which future years may hold on us, seem at such a moment dull and dubious, and are apt to be slighted, for objects on which the daylight is falling strongly, and showing us in all their freshness just within our grasp." Loewenstein also suggests that our memory for the intensity of visceral rewards is deficient: when we put off preparing for that meeting by telling ourselves that we'll do it tomorrow, we fail to take into account that tomorrow the temptation to put off work will be just as strong.

Ignorance might also affect procrastination through what the social scientist Jon Elster calls "the planning fallacy." Elster thinks that people underestimate the time "it will take them to complete a given task, partly because they fail to take account of how long it has taken them to complete similar projects in the past and partly because they rely on smooth scenarios in which accidents or unforeseen problems never occur."

**SubQuestion No : 26**

**Q.26 Which of the following is the meaning that comes CLOSEST to "our memory for the intensity of visceral rewards is deficient" as suggested by Loewenstein?**

- Options**
- A. Our brain partially captures the memory of rewards we get by procrastination.
  - B. Our brain does not capture the intensity of pleasure we get by procrastination.
  - C. Our brain does not differentiate memories of different rewards we get by procrastinating.
  - D. Our brain does not support us with memories which can stop us from procrastinating further.
  - E. Our brain does not support us in recalling intense memories while procrastinating further.

Question ID : **41569919**  
Status : **Answered**  
Chosen Option : **B**

Section : **Decision Making**

**Comprehension:**

**Read the following scenario and answer the TWO questions that follow.**

Moonlighting is the practice of working for one organisation while also accepting additional responsibilities and jobs, typically without the employer's knowledge in another organization. It is named as such because it is typically performed at night or on the weekends. "Doing two remote jobs at once was already happening; it was the biggest open secret out there in tech," said a US techie.

Due to weaker margins, major Indian IT companies such as Infosys, TCS, and Wipro announced that they would delay, postpone, or reduce variable pay-outs to employees for the first quarter of fiscal year 2023. This drew attention to Moonlighting.

The Indian IT industry was divided on the issue of Moonlighting. Some considered it unethical, while others viewed it as an urgent necessity. Infozeta Chairman Patrick's stance on this matter was crystal clear. "There is a great deal of talk about people working part-time in the tech industry. This is cheating, pure and simple," he had tweeted.

However, McMillan, CEO of Betauniverse, does not consider Moonlighting as "cheating".

"Employment is a contract between an employer who pays me for working 'n' number of hours per day," he explained. "Now, what I do after that time is entirely up to me; I can do whatever I please."

**SubQuestion No : 27**

**Q.27 Which of the following options will have the LEAST negative consequence on Moonlighting employees?**

- Options**
- A. Employer reducing daily working hours from eight hours to six hours
  - B. Employees's performance may be adversely affected because of over working
  - C. Increased family problems because employees will not spend quality time at home
  - D. Employer reducing salaries of employees because of Moonlighting
  - E. Poor physical health of employees because of excess work

Question ID : **41569960**  
Status : **Answered**  
Chosen Option : **A**

**Comprehension:**

**Read the following scenario and answer the TWO questions that follow.**

Moonlighting is the practice of working for one organisation while also accepting additional responsibilities and jobs, typically without the employer's knowledge in another organization. It is named as such because it is typically performed at night or on the weekends. "Doing two remote jobs at once was already happening; it was the biggest open secret out there in tech," said a US techie.

Due to weaker margins, major Indian IT companies such as Infosys, TCS, and Wipro announced that they would delay, postpone, or reduce variable pay-outs to employees for the first quarter of fiscal year 2023. This drew attention to Moonlighting.

The Indian IT industry was divided on the issue of Moonlighting. Some considered it unethical, while others viewed it as an urgent necessity. Infozeta Chairman Patrick's stance on this matter was crystal clear. "There is a great deal of talk about people working part-time in the tech industry. This is cheating, pure and simple," he had tweeted.

However, McMillan, CEO of Betauniverse, does not consider Moonlighting as "cheating."

"Employment is a contract between an employer who pays me for working 'n' number of hours per day," he explained. "Now, what I do after that time is entirely up to me; I can do whatever I please."

**SubQuestion No : 28**

**Q.28 Mr. Q is an IT professional who works for a small company in Bangalore. His office hours are from 2:00 p.m. to 10:00 p.m.; thus, he wants to utilize his morning time. He thought of taking up extra work; however, he is not sure about the righteousness of his decision. His company does not have any clear policy on Moonlighting. As he is confused, he seeks opinions of the people who work in his industry to understand ethical dimension of Moonlighting. The following opinions are shared with Mr. Q:**

**Opinion 1: Moonlighting is unacceptable since the employer has a complete right over the employee.**

**Opinion 2: Moonlighting is a choice of the employee, and that the employer has no authority over the employee's conduct after office hours.**

**Opinion 3: Moonlighting leads to employee missing out on important organizational work.**

**Opinion 4: While Moonlighting, the employee might unknowingly leak critical information gained from one organization to the other.**

**Opinion 5: It is OK to Moonlight as employers are exploitative and underpay employees.**

**Given the abovementioned opinions, which of the following combinations will BEST help Mr. Q to realize that Moonlighting is unethical?**

- Options**
- A. Opinions 2 & 3
  - B. Opinions 2 & 5
  - C. Opinions 2 & 4
  - D. Opinions 3 & 4
  - E. Opinions 1 & 5

Question ID : 41569961

Status : Answered

Chosen Option : D

**Comprehension:**

**Read the following scenario and answer the THREE questions that follow.**

Dhan, a poor but enterprising 15-year-old, resided in the world's largest slum in a metropolitan city, along with her widowed mother. The densely packed slum housed about a million people, mostly in rickety one room tenements, connected by labyrinthine lanes and by-lanes. Dhan's mother worked intermittently as a daily wagger in a small savoury factory. For a 15-year-old, Dhan's life was hectic. She spends two hours every day in fetching water for the household, packing breakfast and lunch for her mother. In addition, she had to prepare supper. On her mother's insistence, Dhan also attended an evening bridge school run by an NGO. Dhan's dream was to provide a comfortable life to her mother and take her family out of poverty. Of late, Dhan observed that the customers to a nearby tea-cum-savoury stall (TCS), were mostly the slum dwellers, who thronged the stall for its low prices and lack of alternatives. Further, Dhan gathered that the TCS could not cater to all of its customers, and the owner still made a neat Rs.800 profit per day. Dhan saw that a probable first step towards her family's economic independence could be to own her own TCS.

**SubQuestion No : 29**

**Q.29 From the following, choose the BEST option that will increase Dhan's chances of realising her dream of starting a venture?**

- Options**
- A. Hire someone at Rs.10 per day to fetch water for the household
  - B. Request mother to stop working and be a partner in the new venture
  - C. Stop going to the bridge school
  - D. Request mother to fetch water for the household
  - E. Request mother to pack her own breakfast and lunch

Question ID : **41569937**  
Status : **Answered**  
Chosen Option : **D**



**Comprehension:**

**Read the following scenario and answer the THREE questions that follow.**

Dhan, a poor but enterprising 15-year-old, resided in the world's largest slum in a metropolitan city, along with her widowed mother. The densely packed slum housed about a million people, mostly in rickety one room tenements, connected by labyrinthine lanes and by-lanes. Dhan's mother worked intermittently as a daily wagger in a small savoury factory. For a 15-year-old, Dhan's life was hectic. She spends two hours every day in fetching water for the household, packing breakfast and lunch for her mother. In addition, she had to prepare supper. On her mother's insistence, Dhan also attended an evening bridge school run by an NGO. Dhan's dream was to provide a comfortable life to her mother and take her family out of poverty. Of late, Dhan observed that the customers to a nearby tea-cum-savoury stall (TCS), were mostly the slum dwellers, who thronged the stall for its low prices and lack of alternatives. Further, Dhan gathered that the TCS could not cater to all of its customers, and the owner still made a neat Rs.800 profit per day. Dhan saw that a probable first step towards her family's economic independence could be to own her own TCS.

**SubQuestion No : 30**

**Q.30 Within two years of establishment, Dhan's TCS is not only outcompeting its nearest rivals in the slum but has also earned a goodwill for the quality and taste of its products. Hence, it has become famous within the slum as "Dhan Dhana Dhan" brand. Dhan now aspires to expand the reach of her savouries into the metropolitan region. Dhan wishes to scale up her savoury production from 100 kg to 1000 kg per day while maintaining quality. Dhan realizes that her establishment does not have the space for expansion on its own.**

**Which of the following options will BEST help Dhan to scale up production with least investment, tightly control quality, and also protect her business interests?**

- Options**
- A. Stop catering to the slum dwellers and start serving the metropolitan region exclusively
  - B. Provide the savoury dough and preparation instructions to 100 willing women in the slum and co-opt them as business partners
  - C. Lease space in the metropolitan region and establish a manufacturing unit of TCS
  - D. Outsource the production, along with secret recipes, to a mass savoury production unit outside the slum
  - E. Buy additional space within the slum and establish own manufacturing unit

Question ID : 41569938

Status : Answered

Chosen Option : B

**Comprehension:**

**Read the following scenario and answer the THREE questions that follow.**

Dhan, a poor but enterprising 15-year-old, resided in the world's largest slum in a metropolitan city, along with her widowed mother. The densely packed slum housed about a million people, mostly in rickety one room tenements, connected by labyrinthine lanes and by-lanes. Dhan's mother worked intermittently as a daily wagger in a small savoury factory. For a 15-year-old, Dhan's life was hectic. She spends two hours every day in fetching water for the household, packing breakfast and lunch for her mother. In addition, she had to prepare supper. On her mother's insistence, Dhan also attended an evening bridge school run by an NGO. Dhan's dream was to provide a comfortable life to her mother and take her family out of poverty. Of late, Dhan observed that the customers to a nearby tea-cum-savoury stall (TCS), were mostly the slum dwellers, who thronged the stall for its low prices and lack of alternatives. Further, Dhan gathered that the TCS could not cater to all of its customers, and the owner still made a neat Rs.800 profit per day. Dhan saw that a probable first step towards her family's economic independence could be to own her own TCS.

**SubQuestion No : 31**

**Q.31 Dhan with her ingenuity finds a way to scale up her production capacity on her own terms. Though Dhan's TCS has become the famous "Dhan Dhana Dhan" brand within the slum, it is still unknown to the outside world. Thus, Dhan embarks on the next challenge of creating a market for savouries amongst the masses in the metropolitan region.**

**From the following, choose the BEST option that will help Dhan to sell her products, at the lowest price, to a maximum number of metropolitan customers?**

- Options**
- A. Overwhelm the metropolitan residents with digital advertisements on Instagram.
  - B. Reach out to the malls and high-end retail stores in the metropolitan region through a few marketing executives to sell the products
  - C. Hire a few sales executives to sell products of Dhan Dhana Dhan brand
  - D. Hire a celebrity who currently endorses a diamond jewellery brand to endorse the "Dhan Dhana Dhand" brand
  - E. Engage slum dwellers commuting daily to metropolitan region for work, to sell the products on commission basis

Question ID : **41569939**

Status : **Answered**

Chosen Option : **E**



**Comprehension:**

Go through the following scenario and answer the THREE questions that follow.

To prepare a dish (e.g., Dosa- Sambhar, Idli-chutney, Rajma-Chawal, Mawa-Bati), the chef has to finish nine activities, some of which could be done simultaneously, while others could not be done simultaneously (see diagram). One of the challenges faced by the chef was to precisely calculate the preparation time of a dish and communicate the waiting time to the customers.

However, based on the past data, the chef had an idea about approximate time taken to complete each activity. He had noted down the best (optimistic), worst (pessimistic) and most likely (most commonly observed) time to finish each of the nine activities. Further, the chef realised that frequency of occurrence of most likely time was 66.666%, and the frequency of occurrence of pessimistic and optimistic times were 16.666% each. The diagram below shows the activities involved and the table shows the optimistic, pessimistic, and most likely times for each activity. Time is indicated in minutes in the table below.

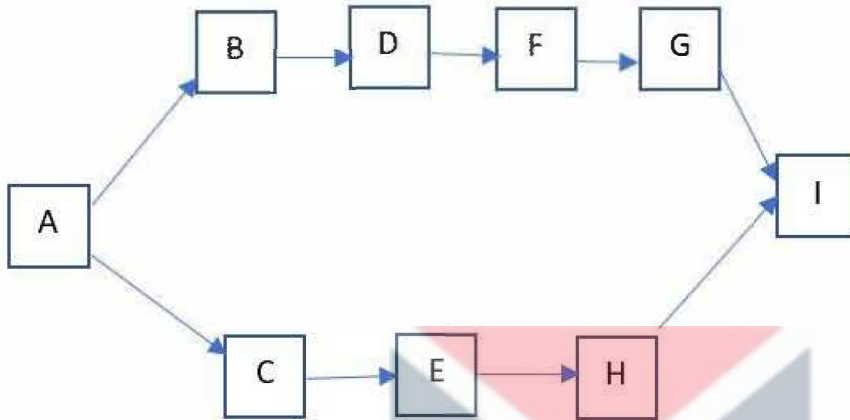

Activity	Optimistic (16.666%)	Pessimistic (16.666%)	Most likely (66.666%)
A	1	1	1
B	2	3	3
C	10	13	12
D	5	5	5
E	3	6	4
F	1	1	1
G	5	10	7
H	9	13	10
I	5	5	5

**SubQuestion No : 32**

**Q.32** The expected time to prepare the dish is the weighted average of optimistic, pessimistic and most likely time.

Which of the following is the expected wait time for the chef to communicate to the customers?

- Options**
- A. Approx. 40.0
  - B. Approx. 47.3
  - C. Approx. 22.0

D. Approx. 51.0  
E. Approx. 32.3

Question ID : **41569949**  
Status : **Answered**  
Chosen Option : **E**



**Comprehension:**

**Go through the following scenario and answer the THREE questions that follow.**

To prepare a dish (e.g., Dosa- Sambhar, Idli-chutney, Rajma-Chawal, Mawa-Bati), the chef has to finish nine activities, some of which could be done simultaneously, while others could not be done simultaneously (see diagram). One of the challenges faced by the chef was to precisely calculate the preparation time of a dish and communicate the waiting time to the customers.

However, based on the past data, the chef had an idea about approximate time taken to complete each activity. He had noted down the best (optimistic), worst (pessimistic) and most likely (most commonly observed) time to finish each of the nine activities. Further, the chef realised that frequency of occurrence of most likely time was 66.666%, and the frequency of occurrence of pessimistic and optimistic times were 16.666% each. The diagram below shows the activities involved and the table shows the optimistic, pessimistic, and most likely times for each activity. Time is indicated in minutes in the table below.

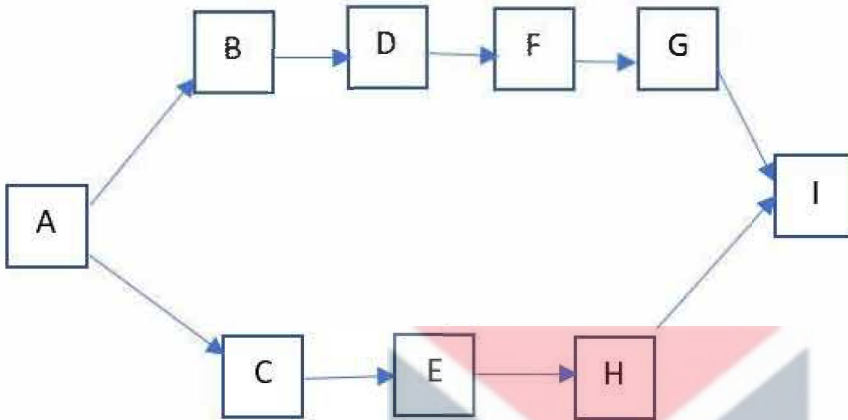

Activity	Optimistic (16.666%)	Pessimistic (16.666%)	Most likely (66.666%)
A	1	1	1
B	2	3	3
C	10	13	12
D	5	5	5
E	3	6	4
F	1	1	1
G	5	10	7
H	9	13	10
I	5	5	5

**SubQuestion No : 33**

**Q.33** Customer dissatisfaction is the difference of actual waiting time (AWT) and expected waiting time (EWT). AWT is the actual time spent by customer before being served the dish. EWT of the customer is the time communicated by the chef.

What is the minimum waiting time (EWT) that the chef should communicate to minimise customer dissatisfaction?

- Options
- A. 42
  - B. 38
  - C. 35
  - D. 40
  - E. 33

Question ID : 41569950  
Status : Answered  
Chosen Option : B



**Comprehension:**

Go through the following scenario and answer the THREE questions that follow.

To prepare a dish (e.g., Dosa- Sambhar, Idli-chutney, Rajma-Chawal, Mawa-Bati), the chef has to finish nine activities, some of which could be done simultaneously, while others could not be done simultaneously (see diagram). One of the challenges faced by the chef was to precisely calculate the preparation time of a dish and communicate the waiting time to the customers.

However, based on the past data, the chef had an idea about approximate time taken to complete each activity. He had noted down the best (optimistic), worst (pessimistic) and most likely (most commonly observed) time to finish each of the nine activities. Further, the chef realised that frequency of occurrence of most likely time was 66.666%, and the frequency of occurrence of pessimistic and optimistic times were 16.666% each. The diagram below shows the activities involved and the table shows the optimistic, pessimistic, and most likely times for each activity. Time is indicated in minutes in the table below.

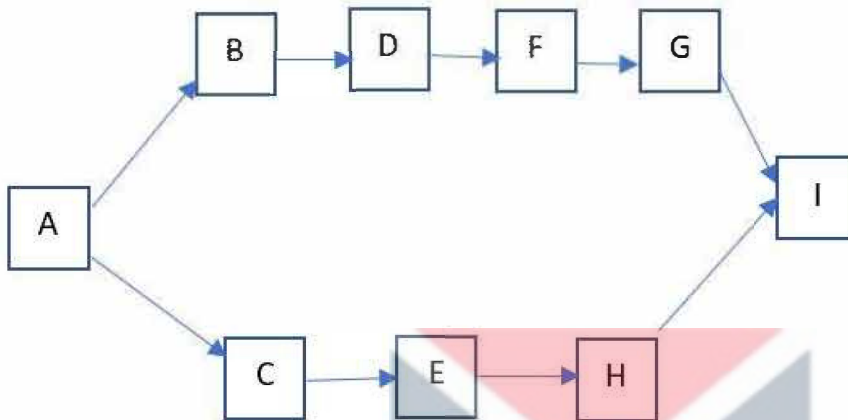

Activity	Optimistic (16.666%)	Pessimistic (16.666%)	Most likely (66.666%)
A	1	1	1
B	2	3	3
C	10	13	12
D	5	5	5
E	3	6	4
F	1	1	1
G	5	10	7
H	9	13	10
I	5	5	5

SubQuestion No : 34

**Q.34** Which of the following is the MOST volatile activity for the chef?

- Options
- A. B
  - B. E
  - C. C
  - D. G
  - E. H

Question ID : 41569951  
Status : Answered  
Chosen Option : D

**Comprehension:**

**Read the following scenario and answer the THREE questions that follow.**

During the floods of 2018-2019, a group of philanthropists led by Niyabuddin, wished to open free food centre for the needy. Their motto was that "no human should be hungry." Nothing gives more satisfaction to the philanthropists than to see the hungry eat to the fullest.

Post Covid-19, the group started a food centre by the name Win Borne Life Care Food (WBLCF) in a small town called Palakkad. The centre started gaining popularity as the number of people enjoying free meals increased over time. Initially, WBLCF offered a standardized menu consisting of idli, upma, puttu for breakfast, curd rice for lunch, and idli or upma for supper. Six women were employed by WBLCF to prepare all the meals. As the number of diners increased, they started expecting a variety in the menu.

At WBLCF, not all the diners eat "free": while two-thirds of diners get free food, one-third would donate some amount to a transparent charity box kept at the entrance. For example, a man donated Rs. 500 after consuming two idlis, and a woman approached Niyabuddin and inquired about donating 10 kilogrammes of rice. Those who could not afford to donate, were often seen prostrating worshipfully in front of the charity box.

Some caring individuals made monetary donation while others donated rice, fruits and vegetables to WBLCF. Further, the centre received enquiries from many locals on how they could contribute to the cause.

As the centre was lauded for its philanthropic work by people of the town, Niyabuddin intended to replicate the initiative in the nearby districts. However, he is concerned about the cost that goes into running the centre. Almost 75 percent of the donated amount goes into buying the cooking ingredients, while the rest goes into paying salaries, operations and maintenance costs.

**SubQuestion No : 35**

**Q.35 From the following, choose the MOST important challenge that Niyabuddin has to overcome to sustain WBLCF.**

- Options**
- A. Preparing only local dishes for diners
  - B. Paying salaries to employees
  - C. Attracting enough diners
  - D. Having enough cooks and employees
  - E. Getting enough finances and donations

Question ID : 41569945  
Status : Answered  
Chosen Option : E

**Comprehension:**

**Read the following scenario and answer the THREE questions that follow.**

During the floods of 2018-2019, a group of philanthropists led by Niyabuddin, wished to open free food centre for the needy. Their motto was that "no human should be hungry." Nothing gives more satisfaction to the philanthropists than to see the hungry eat to the fullest.

Post Covid-19, the group started a food centre by the name Win Borne Life Care Food (WBLCF) in a small town called Palakkad. The centre started gaining popularity as the number of people enjoying free meals increased over time. Initially, WBLCF offered a standardized menu consisting of idli, upma, puttu for breakfast, curd rice for lunch, and idli or upma for supper. Six women were employed by WBLCF to prepare all the meals. As the number of diners increased, they started expecting a variety in the menu.

At WBLCF, not all the diners eat "free": while two-thirds of diners get free food, one-third would donate some amount to a transparent charity box kept at the entrance. For example, a man donated Rs. 500 after consuming two idlis, and a woman approached Niyabuddin and inquired about donating 10 kilogrammes of rice. Those who could not afford to donate, were often seen prostrating worshipfully in front of the charity box.

Some caring individuals made monetary donation while others donated rice, fruits and vegetables to WBLCF. Further, the centre received enquiries from many locals on how they could contribute to the cause.

As the centre was lauded for its philanthropic work by people of the town, Niyabuddin intended to replicate the initiative in the nearby districts. However, he is concerned about the cost that goes into running the centre. Almost 75 percent of the donated amount goes into buying the cooking ingredients, while the rest goes into paying salaries, operations and maintenance costs.

**SubQuestion No : 36**

**Q.36** Niyabuddin realised that on some days the food was wasted while on other days diners went back hungry. He sought advice from a consultant friend on how to reduce wastage. The consultant suggested the following:

1. Launch a mobile app so that diners can pre-inform their arrival to WBLCF.
2. Ask diners who enjoy free meal to distribute excess food to hungry on streets
3. Ask diners to eat less as it is good for health
4. Preach people to eat less
5. Ration amount of food to be served to the diners

**Which of the above ideas will not be consistent with the core ethos of WBLCF?**

- Options**
- A. 2, 3 & 5
  - B. 3, 4 & 5
  - C. 2, 3 & 4
  - D. 1, 2 & 3
  - E. 1, 3 & 4

Question ID : 41569946

Status : Answered

Chosen Option : B

**Comprehension:**

**Read the following scenario and answer the THREE questions that follow.**

During the floods of 2018-2019, a group of philanthropists led by Niyabuddin, wished to open free food centre for the needy. Their motto was that "no human should be hungry." Nothing gives more satisfaction to the philanthropists than to see the hungry eat to the fullest.

Post Covid-19, the group started a food centre by the name Win Borne Life Care Food (WBLCF) in a small town called Palakkad. The centre started gaining popularity as the number of people enjoying free meals increased over time. Initially, WBLCF offered a standardized menu consisting of idli, upma, puttu for breakfast, curd rice for lunch, and idli or upma for supper. Six women were employed by WBLCF to prepare all the meals. As the number of diners increased, they started expecting a variety in the menu.

At WBLCF, not all the diners eat "free": while two-thirds of diners get free food, one-third would donate some amount to a transparent charity box kept at the entrance. For example, a man donated Rs. 500 after consuming two idlis, and a woman approached Niyabuddin and inquired about donating 10 kilogrammes of rice. Those who could not afford to donate, were often seen prostrating worshipfully in front of the charity box.

Some caring individuals made monetary donation while others donated rice, fruits and vegetables to WBLCF. Further, the centre received enquiries from many locals on how they could contribute to the cause.

As the centre was lauded for its philanthropic work by people of the town, Niyabuddin intended to replicate the initiative in the nearby districts. However, he is concerned about the cost that goes into running the centre. Almost 75 percent of the donated amount goes into buying the cooking ingredients, while the rest goes into paying salaries, operations and maintenance costs.

**SubQuestion No : 37**

**Q.37 Niyabuddin wanted to conserve local recipes that can be used to prepare mouth-smacking dishes for the diners.**

**Which of the following could be the BEST way to conserve local recipes?**

- Options**
- A. Tie up with one of food delivery partners to help them document the recipes
  - B. Request a lady once a week in Palakkad to cook food at WBLCF on voluntary basis and document the recipes
  - C. Hold a weekly competition for the best local dish and get it judged and documented by local volunteers
  - D. Tie-up with the chef of the best restaurant in Palakkad to document recipes
  - E. Ask free diners to contribute towards one recipe for a dish and give them the responsibility to document it

Question ID : 41569947

Status : Answered

Chosen Option : C



**Comprehension:**

**Read the following scenario and answer the TWO questions that follow.**

The CEO of the Jamshedpur Tea Factory (JTF) was in a quandary over employees skipping work. It was becoming increasingly difficult for him to identify employees who faked illness to skip work. The work of the employees was complex and intricate, and they had to report to eight supervisors. "Faking illness" made it difficult for JTF to judiciously decide on "Promotion" and "Training" of employees. An employee could only be promoted on the completion of a multi-skilling training program. Further, to be nominated for the training program, an employee must be recommended by a minimum of six supervisors. JTF wanted to promote only sincere and deserving employees.

**SubQuestion No : 38**

**Q.38 The CEO was thinking of changing the policy regarding leave, training & promotion. Which of the following will be the MOST efficient course of action for JTF and yet be fair to the employees?**

- Options**
- A. Let supervisors decide on the leave of an employee.
  - B. Let the CEO office decide on leave but supervisors will recommend promotions.
  - C. Let the CEO office decide on promotion but each supervisor will decide on the leave.
  - D. Let status quo continue
  - E. Let the CEO office decide on the leave as well as promotions.

Question ID : 41569957

Status : Not Answered

Chosen Option : --

**Comprehension:**

**Read the following scenario and answer the TWO questions that follow.**

The CEO of the Jamshedpur Tea Factory (JTF) was in a quandary over employees skipping work. It was becoming increasingly difficult for him to identify employees who faked illness to skip work. The work of the employees was complex and intricate, and they had to report to eight supervisors. "Faking illness" made it difficult for JTF to judiciously decide on "Promotion" and "Training" of employees. An employee could only be promoted on the completion of a multi-skilling training program. Further, to be nominated for the training program, an employee must be recommended by a minimum of six supervisors. JTF wanted to promote only sincere and deserving employees.

**SubQuestion No : 39**

**Q.39 Which of the following policies will be MOST prone to error while selecting deserving and sincere employees?**

- Options**
- A. Outsource all leave decisions to a doctor whose judgment will be final
  - B. Let the CEO office decide on the leave as well as promotions.
  - C. Let the CEO office decide on leave but supervisors will recommend the promotion.
  - D. Let the CEO office decide on promotions but supervisors will decide on the leave.
  - E. Outsource all leave decisions to a lawyer whose judgement will be final

Question ID : 41569958

Status : Answered

Chosen Option : E

**Comprehension:**

**Read the following scenario and answer the THREE questions that follow.**

Bharat Business School (BBS), a premier business school, was renowned for the quality education it provided. Its faculty, known for their domain area expertise and excellence in teaching, competed with each other for a better student feedback. Of late, the institute was finding it difficult to upgrade its course content with rapidly changing global business scenario. The difficulties multiplied when the school realized that some of senior faculty would retire on regular basis, starting in the near future. To overcome these difficulties, BBS decided to recruit young faculty in all the departments (e.g., Economics, Finance, Marketing, HRM, Production etc).

When the Dean - Academics scanned the applications, she found three distinct types of aspirants viz. (i) A type candidates who were very good teachers, competent at teaching the courses taught by existing faculty members; (ii) B type candidates who were average teachers, competent at creating and teaching new courses that would complement existing courses, taught by the current faculty; (iii) C type candidates were not-so-good teachers, willing to teach any course BBS required.

Note1: A course is termed complementary when it covers latest content and complements existing courses offered by a department.

Note2: Each department decides the suite of courses to be offered.

**SubQuestion No : 40**

**Q.40 Given the above context, which of the following options will be the BEST recruitment decision for BBS?**

- Options**
- A. Hire A type candidates on a condition that they will have to develop complementary courses.
  - B. Hire B type candidates so that all types of courses can be offered to students
  - C. Hire A type candidates unconditionally and allow them to teach courses taught by the existing faculty
  - D. Hire C type candidates, as they can teach any course
  - E. Don't recruit and request the existing faculty to develop complementary courses

Question ID : 41569933

Status : Answered

Chosen Option : A

**Comprehension:**

**Read the following scenario and answer the THREE questions that follow.**

Bharat Business School (BBS), a premier business school, was renowned for the quality education it provided. Its faculty, known for their domain area expertise and excellence in teaching, competed with each other for a better student feedback. Of late, the institute was finding it difficult to upgrade its course content with rapidly changing global business scenario. The difficulties multiplied when the school realized that some of senior faculty would retire on regular basis, starting in the near future. To overcome these difficulties, BBS decided to recruit young faculty in all the departments (e.g., Economics, Finance, Marketing, HRM, Production etc).

When the Dean - Academics scanned the applications, she found three distinct types of aspirants viz. (i) A type candidates who were very good teachers, competent at teaching the courses taught by existing faculty members; (ii) B type candidates who were average teachers, competent at creating and teaching new courses that would complement existing courses, taught by the current faculty; (iii) C type candidates were not-so-good teachers, willing to teach any course BBS required.

Note1: A course is termed complementary when it covers latest content and complements existing courses offered by a department.

Note2: Each department decides the suite of courses to be offered.

**SubQuestion No : 41**

**Q.41 Suppose the Dean - Academics wanted to reduce future conflicts and political manoeuvring to ensure harmony among faculty.**

**Which of the following options will BEST reduce conflicts and politicking amongst the faculty?**

- Options**
- A. Hire B type candidates and allow them to teach all kinds of courses
  - B. Hire A type candidates to teach existing courses and ask existing faculty to teach new courses
  - C. Hire C type candidates and allow them to teach all types of courses
  - D. Hire A type candidates, and let the new as well as existing faculty offer same courses
  - E. Hire B type candidates to teach complementary courses

Question ID : **41569934**

Status : **Not Answered**

Chosen Option : --

**Comprehension:**

**Read the following scenario and answer the THREE questions that follow.**

Bharat Business School (BBS), a premier business school, was renowned for the quality education it provided. Its faculty, known for their domain area expertise and excellence in teaching, competed with each other for a better student feedback. Of late, the institute was finding it difficult to upgrade its course content with rapidly changing global business scenario. The difficulties multiplied when the school realized that some of senior faculty would retire on regular basis, starting in the near future. To overcome these difficulties, BBS decided to recruit young faculty in all the departments (e.g., Economics, Finance, Marketing, HRM, Production etc).

When the Dean - Academics scanned the applications, she found three distinct types of aspirants viz. (i) A type candidates who were very good teachers, competent at teaching the courses taught by existing faculty members; (ii) B type candidates who were average teachers, competent at creating and teaching new courses that would complement existing courses, taught by the current faculty; (iii) C type candidates were not-so-good teachers, willing to teach any course BBS required.

Note1: A course is termed complementary when it covers latest content and complements existing courses offered by a department.

Note2: Each department decides the suite of courses to be offered.

**SubQuestion No : 42**

**Q.42 Suppose the Dean-Academics wanted to ensure the most efficient utilization of faculty resources. Which of the following hiring decisions will ensure the MOST efficient utilization of faculty resources?**

- Options**
- A. Hire C type candidates and assign them teaching-assistant responsibilities
  - B. Hire A type candidates and let the new as well as existing faculty teach same courses
  - C. Hire B type candidates to teach complementary courses
  - D. Ask existing faculty to develop complementary courses
  - E. Hire A type candidates, capable of developing complementary courses

Question ID : 41569935  
Status : Answered  
Chosen Option : E

**Comprehension:**

**Read the following scenario and answer the THREE questions that follow.**

In recent years, complaints of sexual harassment at "Fair Consulting" had increased exponentially. Fair Consulting had a gender-neutral, anti-sexual harassment policy and a committee to adjudicate on complaints. During the hearing of complaints, allegations and counter-allegations would fly thick and fast. This made it difficult for the adjudicating committee to conclusively decide on the complaints.

**SubQuestion No : 43**

**Q.43 Fair Consulting was mulling over three interventions to reduce sexual harassment cases in the workplace. They are:**

1. Educate employees about the company's anti-sexual harassment policy
2. Profile employees with a propensity to engage in acts of sexual harassment
3. Discipline sexual offenders

**Which of the following options will the employees find LEAST ostracizing?**

- Options**
- A. 1 Only
  - B. 2 & 3
  - C. 1 & 2
  - D. 2 Only
  - E. 3 Only

Question ID : 41569941  
Status : Answered  
Chosen Option : A

**Comprehension:**

**Read the following scenario and answer the THREE questions that follow.**

In recent years, complaints of sexual harassment at "Fair Consulting" had increased exponentially. Fair Consulting had a gender-neutral, anti-sexual harassment policy and a committee to adjudicate on complaints. During the hearing of complaints, allegations and counter-allegations would fly thick and fast. This made it difficult for the adjudicating committee to conclusively decide on the complaints.

**SubQuestion No : 44**

**Q.44 The CEO of Fair Consulting wanted the adjudicating committee to reduce the number of errors while deciding on sexual harassment complaints. The employees suggested that the committee could do the following to reduce errors in judgment.**

1. Listen to the arguments of both the complainant and the accused together
2. Listen to the arguments of both the complainant and the accused separately
3. Involve a member of women's commission
4. Take the help of a retired judge
5. Hire a forensic expert to verify evidences

**From the following, choose the MOST effective sequence that would help the committee to arrive at the right decision.**

- Options**
- A. 1, 2, 3
  - B. 2, 1, 5
  - C. 2, 4, 1
  - D. 1, 2, 4
  - E. 2, 3, 4

Question ID : **41569942**  
Status : **Answered**  
Chosen Option : **D**

**Comprehension:**

**Read the following scenario and answer the THREE questions that follow.**

In recent years, complaints of sexual harassment at "Fair Consulting" had increased exponentially. Fair Consulting had a gender-neutral, anti-sexual harassment policy and a committee to adjudicate on complaints. During the hearing of complaints, allegations and counter-allegations would fly thick and fast. This made it difficult for the adjudicating committee to conclusively decide on the complaints.

**SubQuestion No : 45**

**Q.45 Of late, the adjudicating committee received a complaint from a junior female consultant. Her immediate boss cracked a bawdy joke about her in the office tuck shop. When the committee probed the alleged misconduct, they identified an independent witness. She agreed to give her testimony to the committee: however, she was unsure if she would like to be identified either by the complainant or the accused. The convenor of the committee was confused about the stance to be taken on the witness's concern.**

**Which of the following will be the BEST stance to be taken by the convenor?**

- Options**
- A. The convenor should not allow witness's identity to be revealed because complainant can sabotage the inquiry process.
  - B. The convenor should not allow witness's identity to be revealed as either the accused or the complainant can use the witness's arguments to their advantage.
  - C. The convenor should not let witness's identity be revealed as it might expose her to a threat either from the respondent or the accused.
  - D. The convenor should ensure that the witness identifies herself because both the accused and the complainant must identify themselves.
  - E. The convenor should ensure that witness identify herself as it will ensure that she will not present frivolous proof related to the inquiry.

Question ID : **41569943**  
Status : **Answered**  
Chosen Option : **B**

**Comprehension:**

**Read the following scenario and answer the THREE questions that follow.**

Arti, CEO of an FMCG company, was under pressure from the Board of Governors (BoG) to increase diversity in the workforce. The board wanted the company to hire candidates with vision impairment\*, as it believed that they contributed to organizations in many unique ways.

The CEO was apprehensive of hiring visually impaired candidates; she was not sure about the feasibility of accommodating them in the current setting. Moreover, Arti was unsure as to how the visually impaired could contribute meaningfully to the organization.

(\* A person, with a vision impairment in a range of 60-100 percent, is referred to as a visually impaired person. A person with 100 percent vision impairment cannot see at all.)

**SubQuestion No : 46**

**Q.46 The following arguments were presented to Arti about the candidates with vision impairment:**

- 1. Visually impaired can do some activities better than the normal people and hence complement other employees.**
- 2. Visually impaired can motivate other employees to work harder.**
- 3. Visually impaired can act as a role model for other disadvantaged people in the society**
- 4. Visually impaired can work harder to prove themselves**
- 5. Hiring visually impaired people may enhance organizational reputation which may consequently lead to better sales.**
- 6. Visually impaired have to be paid 20 percent extra salary.**

**From the above arguments, which of the following options indicate that CEO's apprehensions are misplaced?**

- Options**
- A. 1,2,4,6 Only
  - B. 1,2,4,5 Only
  - C. 1,2,3,4,5&6
  - D. 1,2,3,4 Only
  - E. 1,2,3,4,5 Only



Question ID : **41569953**  
Status : **Answered**  
Chosen Option : **B**

**Comprehension:**

**Read the following scenario and answer the THREE questions that follow.**

Arti, CEO of an FMCG company, was under pressure from the Board of Governors (BoG) to increase diversity in the workforce. The board wanted the company to hire candidates with vision impairment\*, as it believed that they contributed to organizations in many unique ways.

The CEO was apprehensive of hiring visually impaired candidates; she was not sure about the feasibility of accommodating them in the current setting. Moreover, Arti was unsure as to how the visually impaired could contribute meaningfully to the organization.

(\* A person, with a vision impairment in a range of 60-100 percent, is referred to as a visually impaired person. A person with 100 percent vision impairment cannot see at all.)

**SubQuestion No : 47**

**Q.47** Arti wanted to follow the suggestion given by the Board of Governors; however, she was not sure if the company was ready to accommodate candidates with 100 percent visual impairment. Also, the concern of involving such employees in meaningful activities was constantly bothering her. Hence, she constituted a committee to come up with recommendations that would help the company in hiring 100 percent visually impaired employees

After two months of deliberations, the committee came up with the following recommendations:

1. Hire visually impaired employees unconditionally as it is any company's social responsibility
2. Hire visually impaired employees in the activities they can contribute
3. Ensure visually impaired friendly office space, food courts, restrooms, parking etc.
4. Allow guide dogs to assist employees with 100 percent vision impairment in the office premises

Which of the following options will BEST allay concerns as well as be fair to all stakeholders?

- Options
- A. 2, 3 & 4 Only
  - B. 1 & 3 Only
  - C. 3 & 4 Only
  - D. 1, 2 & 3 Only
  - E. 1, 3 & 4 Only



Question ID : 41569954

Status : Answered

Chosen Option : A

**Comprehension:**

**Read the following scenario and answer the THREE questions that follow.**

Arti, CEO of an FMCG company, was under pressure from the Board of Governors (BoG) to increase diversity in the workforce. The board wanted the company to hire candidates with vision impairment\*, as it believed that they contributed to organizations in many unique ways.

The CEO was apprehensive of hiring visually impaired candidates; she was not sure about the feasibility of accommodating them in the current setting. Moreover, Arti was unsure as to how the visually impaired could contribute meaningfully to the organization.

(\* A person, with a vision impairment in a range of 60-100 percent, is referred to as a visually impaired person. A person with 100 percent vision impairment cannot see at all.)

**SubQuestion No : 48**

**Q.48 Suresh refuses to be served coffee by visually impaired baristas, but he does believe in donating to the visually impaired. The following statements could explain why Suresh does not want to be served by visually impaired baristas.**

- 1. He thinks that visually impaired are inefficient at serving coffee.**
  - 2. His parents have taught him to donate, instead of accepting services from challenged individuals.**
  - 3. He believes that his refusal to be served will have adverse consequences.**
  - 4. He feels joyous amongst visually impaired; sharing his life and caring for them.**
- From the following, choose the option that BEST explains Suresh's biased behaviour.**

- Options**
- A. 2,3,4 Only
  - B. 1,2,4 Only
  - C. 1,2 Only
  - D. 1,3,4 Only
  - E. 1,2,3,4

Question ID : 41569955  
Status : Answered  
Chosen Option : C

Section : Quantitative Aptitude and Data Interpretation

**Q.49 Five students appeared for an examination. The average mark obtained by these five students is 40. The maximum mark of the examination is 100, and each of the five students scored more than 10 marks. However, none of them scored exactly 40 marks. Based on the information given, which of the following MUST BE true?**

- Options**
- A. At least, three of them scored a maximum of 40 marks
  - B. At least, three of them scored more than 40 marks
  - C. At least, one of them scored exactly 41 marks
  - D. At most, two of them scored more than 40 marks
  - E. At least, one of them scored less than 40 marks

Question ID : 41569971  
Status : Answered  
Chosen Option : E



**Q.50** There are three sections in a question paper and each section has 10 questions. First section only has multiple-choice questions, and 2 marks will be awarded for each correct answer. For each wrong answer, 0.5 marks will be deducted. Any un-attempted question in this section will be treated as a wrong answer. Each question in the second section carries 3 marks, whereas each question in the third section carries 5 marks. For any wrong answer or un-attempted question in the second and third sections, no marks will be deducted. A student's score is the addition of marks obtained in all the three sections. What is the sixth highest possible score?

- Options**
- A. 92.5
  - B. 94
  - C. 95.5
  - D. 95
  - E. None of the above.

Question ID : **41569970**  
 Status : **Answered**  
 Chosen Option : **A**

**Q.51** Consider  $a_{n+1} = \frac{1}{1+a_n}$  for  $n = 1, 2, \dots, 2008, 2009$  where  $a_1 = 1$ . Find the value of  $a_1a_2 + a_2a_3 + a_3a_4 + \dots + a_{2008}a_{2009}$ .

- Options**
- A.  $\frac{2009}{1000}$
  - B.  $\frac{2009}{2008}$
  - C.  $\frac{2008}{2009}$
  - D.  $\frac{6000}{2009}$
  - E.  $\frac{2008}{6000}$



Question ID : **41569963**  
 Status : **Answered**  
 Chosen Option : **C**

**Q.52** The problem below consists of a question and two statements numbered 1 & 2. You have to decide whether the data provided in the statements are sufficient to answer the question.

Rahim is riding upstream on a boat, from point A to B, at a constant speed. The distance from A to B is 30 km. One minute after Rahim leaves from point A, a speedboat starts from point A to go to point B. It crosses Rahim's boat after 4 minutes. If the speed of the speedboat is constant from A to B, what is Rahim's speed in still water?

1. The speed of the speedboat in still water is 30 km/hour.
2. Rahim takes three hours to reach point B from point A.

- Options**
- A. Statement 1 alone is sufficient to answer the question, but statement 2 alone is not sufficient
  - B. Statement 2 alone is sufficient to answer the question, but statement 1 alone is not sufficient
  - C. Each statement alone is sufficient
  - D. Both statements together are sufficient, but neither of them alone is sufficient
  - E. Statements 1 & 2 together are not sufficient

Question ID : 41569976

Status : Not Answered

Chosen Option : --

**Q.53** Find the value of:

$$\frac{\sin^6 15^\circ + \sin^6 75^\circ + 6\sin^2 15^\circ \sin^2 75^\circ}{\sin^4 15^\circ + \sin^4 75^\circ + 5\sin^2 15^\circ \sin^2 75^\circ}$$

- Options**
- A.  $\sin 15^\circ + \sin 75^\circ$
  - B.  $6/5$
  - C. 1
  - D.  $\sin 15^\circ \cos 15^\circ$
  - E. None of the above

Question ID : 41569979

Status : Answered

Chosen Option : C

**Q.54** A small jar contained water, lime and sugar in the ratio of 90:7:3. A glass contained only water and sugar in it. Contents of both (small jar and glass) were mixed in a bigger jar and the ratio of contents in the bigger jar was 85:5:10 (water, lime and sugar respectively). Find the percentage of water in the bigger jar?

- Options**
- A. 70
  - B. 75
  - C. 80
  - D. 72.5
  - E. 85

Question ID : 41569980

Status : Answered

Chosen Option : E

**Q.55** Rajnish bought an item at 25% discount on the printed price. He sold it at 10% discount on the printed price. What is his profit in percentage?

- Options
- A. 10
  - B. 15
  - C. 17.5
  - D. 20
  - E. None of the above

Question ID : 41569974  
Status : Answered  
Chosen Option : D

**Q.56** The addition of 7 distinct positive integers is 1740. What is the largest possible "greatest common divisor" of these 7 distinct positive integers?

- Options
- A. 42
  - B. 60
  - C. 74
  - D. 140
  - E. None of the above.

Question ID : 41569978  
Status : Not Answered  
Chosen Option : --

**Q.57** Separately, Jack and Sristi invested the same amount of money in a stock market. Jack's invested amount kept getting reduced by 50% every month. Sristi's investment also reduced every month, but in an arithmetic progression with a common difference of Rs. 15000. They both withdrew their respective amounts at the end of the sixth month. They observed that if they had withdrawn their respective amounts at the end of the fourth month, the ratio of their amounts would have been the same as the ratio after the sixth month. What amount of money was invested by Jack in the stock market?

- Options
- A. Rs. 100000
  - B. Rs. 120000
  - C. Rs. 150000
  - D. Rs. 180000
  - E. None of the above

Question ID : 41569973  
Status : Answered  
Chosen Option : A

**Q.58** Given  $A = |x + 3| + |x - 2| - |2x - 8|$ . The maximum value of  $|A|$  is:

- Options
- A. 111
  - B. 9
  - C. 6
  - D. 3
  - E.  $\infty$

Question ID : 41569975  
Status : Answered  
Chosen Option : B

**Q.59** ABC is a triangle and the coordinates of A, B and C are  $(a, b-2c)$ ,  $(a, b+4c)$  and  $(-2a, 3c)$  respectively where a, b and c are positive numbers. The area of the triangle ABC is:

- Options
- A.  $6abc$
  - B.  $9abc$
  - C.  $6bc$
  - D.  $9ac$
  - E. None of the above

Question ID : 41569966  
Status : Answered  
Chosen Option : E

**Q.60** A non-flying ant wants to travel from the bottom corner to the diagonally opposite top corner of a cubical room. The side of the room is 2 meters. What will be the minimum distance that the ant needs to travel?

- Options
- A. 6 meters
  - B.  $(2\sqrt{2}+2)$  meters
  - C.  $2\sqrt{3}$  meters
  - D.  $2\sqrt{6}$  meters
  - E.  $2\sqrt{5}$  meters

Question ID : 41569983  
Status : Answered  
Chosen Option : B

**Q.61** A painter draws 64 equal squares of 1 square inch on a square canvas measuring 64 square inches. She chooses two squares (1 square inch each) randomly and then paints them. What is the probability that two painted squares have a common side?

- Options
- A.  $\frac{112}{2016}$
  - B.  $\frac{1}{3}$
  - C.  $\frac{512}{100034}$
  - D.  $\frac{3}{97}$
  - E.  $\frac{7}{108}$

Question ID : 41569981  
Status : Answered  
Chosen Option : A

**Q.62** ABC is a triangle with  $BC = 5$ . D is the foot of the perpendicular from A on BC. E is a point on CD such that  $BE = 3$ . The value of  $AB^2 - AE^2 + 6CD$  is:

- Options
- A. 5
  - B. 10
  - C. 14
  - D. 18
  - E. 21

Question ID : 41569965  
Status : Not Answered  
Chosen Option : --

**Q.63** Let  $x$  and  $y$  be two positive integers and  $p$  be a prime number. If  $x(x - p) - y(y + p) = 7p$ , what will be the minimum value of  $x - y$ ?

- Options
- A. 1
  - B. 3
  - C. 5
  - D. 7
  - E. None of the above

Question ID : 41569967  
Status : Not Answered  
Chosen Option : --

**Q.64** Amit has forgotten his 4-digit locker key. He remembers that all the digits are positive integers and are different from each other. Moreover, the fourth digit is the smallest and the maximum value of the first digit is 3. Also, he recalls that if he divides the second digit by the third digit, he gets the first digit. How many different combinations does Amit have to try for unlocking the locker?

- Options
- A. 2
  - B. 1
  - C. 4
  - D. 5
  - E. 3

Question ID : 41569964  
Status : Answered  
Chosen Option : E

**Q.65** The problem below consists of a question and two statements numbered 1 & 2. You have to decide whether the data provided in the statements are sufficient to answer the question.

In a cricket match, three slip fielders are positioned on a straight line. The distance between 1st slip and 2nd slip is the same as the distance between 2nd slip and the 3rd slip. The player X, who is not on the same line of slip fielders, throws a ball to the 3rd slip and the ball takes 5 seconds to reach the player at the 3rd slip. If he had thrown the ball at the same speed to the 1st slip or to the 2nd slip, it would have taken 3 seconds or 4 seconds, respectively. What is the distance between the 2nd slip and the player X?

1. The ball travels at a speed of 3.6 km/hour.
2. The distance between the 1st slip and the 3rd slip is 2 meters.

- Options**
- A. Statement 1 alone is sufficient to answer the question, but statement 2 alone is not sufficient
  - B. Statement 2 alone is sufficient to answer the question, but statement 1 alone is not sufficient
  - C. Each statement alone is sufficient
  - D. Both statements together are sufficient, but neither of them alone is sufficient
  - E. Statements 1 & 2 together are not sufficient

Question ID : 41569977

Status : Not Answered

Chosen Option : --

**Q.66** Raju and Sarita play a number game. First, each one of them chooses a positive integer independently. Separately, they both multiply their chosen integers by 2, and then subtract 20 from their resultant numbers. Now, each of them has a new number. Then, they divide their respective new numbers by 5. Finally, they added their results and found that the sum is 16. What can be the maximum possible difference between the positive integers chosen by Raju and Sarita?

- Options**
- A. 67
  - B. 58
  - C. 49
  - D. 40
  - E. None of the above

Question ID : 41569969

Status : Answered

Chosen Option : B

**Q.67** ABCD is a trapezoid where BC is parallel to AD and perpendicular to AB. Kindly note that  $BC < AD$ . P is a point on AD such that CPD is an equilateral triangle. Q is a point on BC such that AQ is parallel to PC. If the area of the triangle CPD is  $4\sqrt{3}$ , find the area of the triangle ABQ.

Options

A.  $2\sqrt{3}$

B.  $4\sqrt{3}$

C. 4

D.  $8\sqrt{3}$

E. None of the above

Question ID : 41569972

Status : Answered

Chosen Option : A

**Q.68** Suppose Haruka has a special key  $\Delta$  in her calculator called delta key:

Rule 1: If the display shows a one-digit number, pressing delta key  $\Delta$  replaces the displayed number with twice its value.

Rule 2: If the display shows a two-digit number, pressing delta key  $\Delta$  replaces the displayed number with the sum of the two digits.

Suppose Haruka enters the value 1 and then presses delta key  $\Delta$  repeatedly. After pressing the  $\Delta$  key for 68 times, what will be the displayed number?

Options A. 7

B. 4

C. 10

D. 2

E. 8

Question ID : 41569962

Status : Answered

Chosen Option : A

**Q.69** The Guava club has won 40% of their football matches in the Apple Cup that they have played so far. If they play another  $n$  matches and win all of them, their winning percentage will improve to 50. Further, if they play 15 more matches and win all of them, their winning percentage will improve from 50 to 60. How many matches has the Guava club played in the Apple Cup so far? In the Apple Cup matches, there are only two possible outcomes, win or loss; draw is not possible.

Options A. 50

B. 40

C. 30

D. Cannot be determined, as the value of  $n$  is not given

E. 60

Question ID : 41569968

Status : Answered

Chosen Option : A

**Q.70** Jose borrowed some money from his friend at simple interest rate of 10% and invested the entire amount in stocks. At the end of the first year, he repaid  $\frac{1}{5}$ th of the principal amount. At the end of the second year, he repaid half of the remaining principal amount. At the end of third year, he repaid the entire remaining principal amount. At the end of the fourth year, he paid the last three years' interest amount. As there was no principal amount left, his friend did not charge any interest in the fourth year. At the end of fourth year, he sold out all his stocks. Later, he calculated that he gained Rs. 97500 after paying principal and interest amounts to his friend. If his invested amount in the stocks became double at the end of the fourth year, how much money did he borrow from his friend?

- Options**
- A. 250000
  - B. 200000
  - C. 150000
  - D. 125000
  - E. None of the above

Question ID : 41569982

Status : Not Answered

Chosen Option : --





**Comprehension:**

Go through the information given below, and answer the THREE questions that follow.

The three graphs below capture relationship between economic (and social) activities and subjective well-being. The first graph (Graph-1) captures relationship between GDP (per-capita) and Satisfaction with life, across different countries and four islands: Gizo, Roviana, Nijhum Dwip, and Chittagong. The Graph-2 captures three different measures of subjective well-being (Satisfaction with life, Affect Balance and Momentary Affect) across the four islands, which have different levels monetization (Index). The Graph-3 captures levels of thirteen different socio-economic activities across four islands.

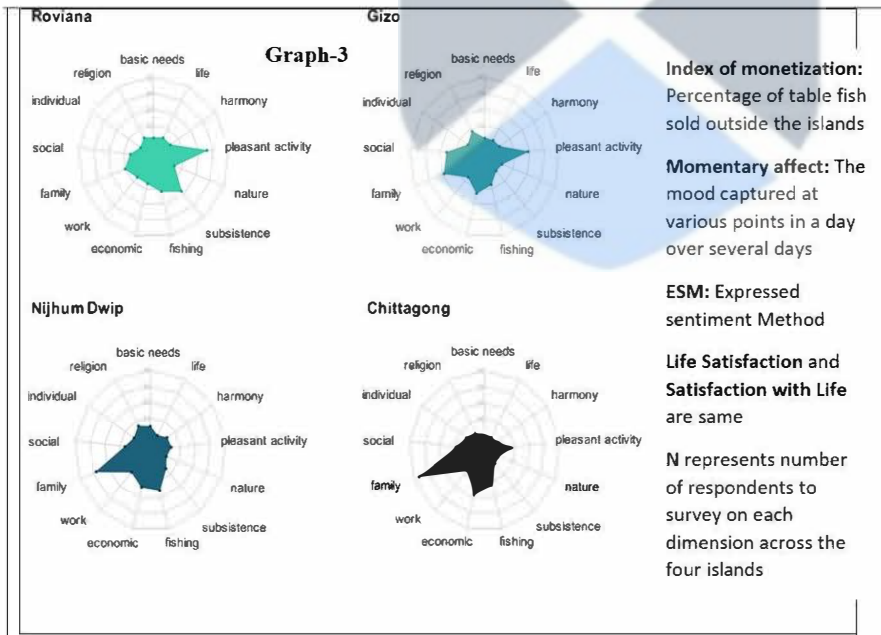
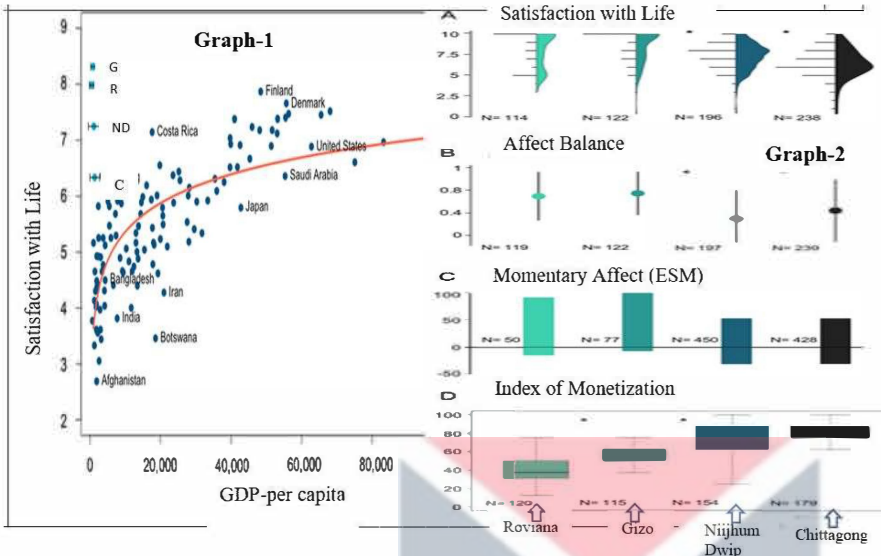

SubQuestion No : 71

Q.71 Which of the following will BEST capture the relationship between GDP (x-axis) and Life Satisfaction (y-axis) of countries?

Options

A.  $y = x$

B.  $y = x^2$

C.  $y = \log(x)$

D.  $y = \frac{1}{x^2}$

E.  $y = e^x$

Question ID : 41569985

Status : Answered

Chosen Option : A



**Comprehension:**

Go through the information given below, and answer the THREE questions that follow.

The three graphs below capture relationship between economic (and social) activities and subjective well-being. The first graph (Graph-1) captures relationship between GDP (per-capita) and Satisfaction with life, across different countries and four islands: Gizo, Roviana, Nijhum Dwip, and Chittagong. The Graph-2 captures three different measures of subjective well-being (Satisfaction with life, Affect Balance and Momentary Affect) across the four islands, which have different levels monetization (Index). The Graph-3 captures levels of thirteen different socio-economic activities across four islands.

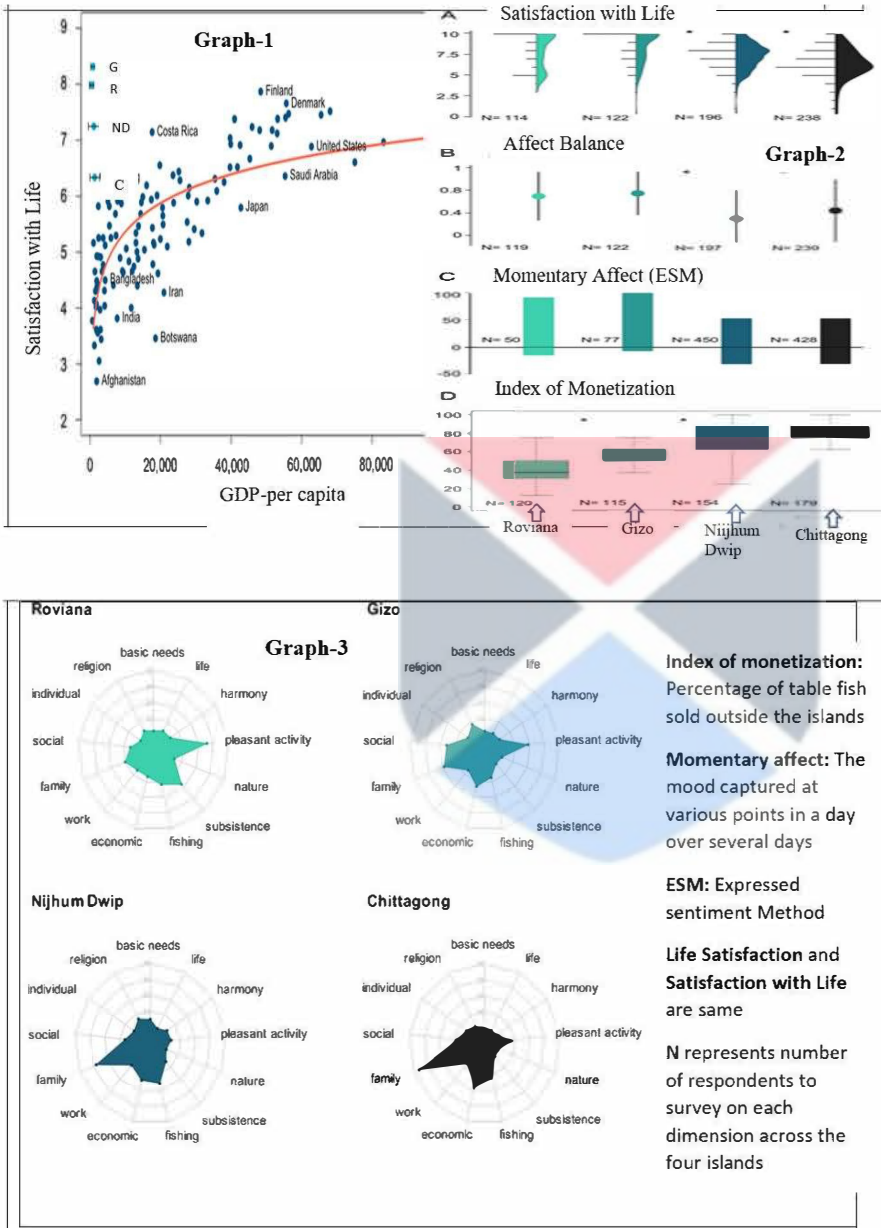

**SubQuestion No : 72**

**Q.72** Which of the following, about the four islands, can be BEST inferred from the graphs?

- Options**
- A. Whenever affect balance increases, satisfaction with life decreases
  - B. Whenever Pleasant activities increase, satisfaction with life decreases
  - C. Whenever Religion increases, satisfaction with life decreases
  - D. Whenever satisfaction with life increases, family also increases
  - E. Index of monetization varies maximum in Nijhum Dwip



**Comprehension:**

Go through the information given below, and answer the THREE questions that follow.

The three graphs below capture relationship between economic (and social) activities and subjective well-being. The first graph (Graph-1) captures relationship between GDP (per-capita) and Satisfaction with life, across different countries and four islands: Gizo, Roviana, Nijhum Dwip, and Chittagong. The Graph-2 captures three different measures of subjective well-being (Satisfaction with life, Affect Balance and Momentary Affect) across the four islands, which have different levels monetization (Index). The Graph-3 captures levels of thirteen different socio-economic activities across four islands.

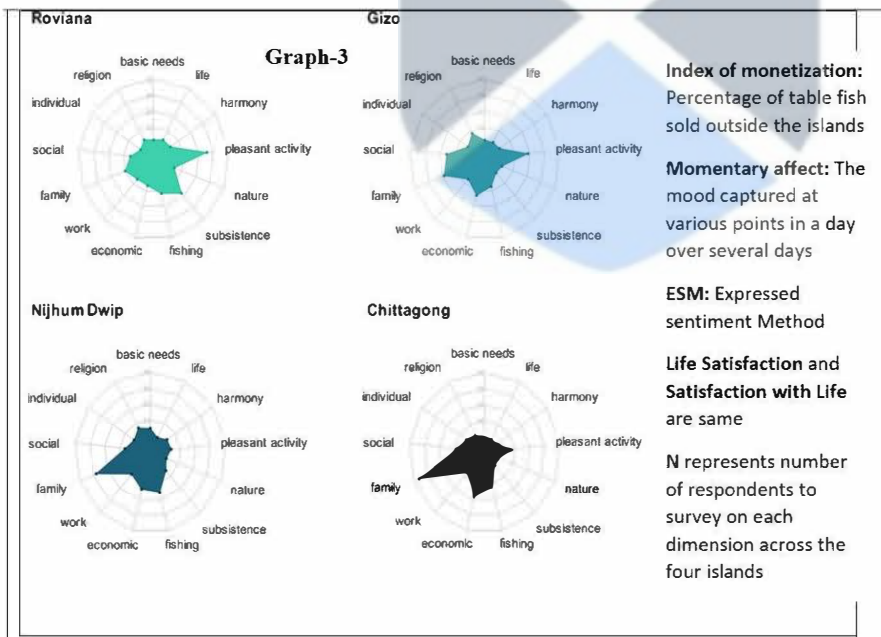
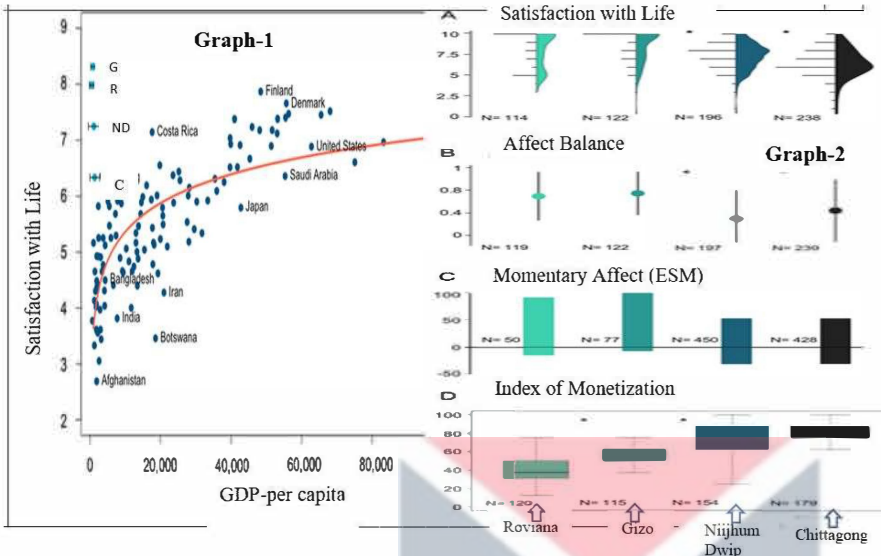

SubQuestion No : 73

Q.73 Which of the following site has the highest fishing to economic ratio?

- Options
- A. Gizo
  - B. Chittagong
  - C. Roviana
  - D. Nijhum Dwip
  - E. All four islands have equal dependence

**Comprehension:**

Go through the information given below, and answer the **THREE** questions that follow.

The table captures *Age* and *Gender* distribution of Covid Positive Cases in a country. However, a part of data is missing, represented through unknown categories.

		<b>Gender</b>			
		<i>Total Confirmed Covid Positive Cases</i>	<i>Female</i>	<i>Male</i>	<i>Unknown</i>
<b>Age</b>	<i>All</i>	117,586*	62,434	53,825	1,327
	<i>Unknown</i>	235			
	<i>0-18</i>	22,362	11,147	10,880	
	<i>19-30</i>	32,860	18,768	13,743	
	<i>31-40</i>	24,110	12,693	11,118	
	<i>41-50</i>	14,120	7,264	6,688	
	<i>51-60</i>	11,174	5,567	5,523	
	<i>61-70</i>	7,300	3,756	3,513	
	<i>71-80</i>	3,429	1,875	1,534	
	<i>81+</i>	1,996	1,276	708	

\*Includes <5 cases in age group 19-30 and 51-60 who reported gender as Other/Transgender.  
 \* In unknown age category, the ratio of males (unknown age category) and females (unknown age category) to total unknown cases (unknown age category) is same as the ratio of males (All) and females (All) to the total (Total Confirmed Covid Positive Cases).

**SubQuestion No : 74**

**Q.74** In unknown age category, the ratio of males (unknown age category) and females (unknown age category) to total unknown cases (unknown age category) is same as the ratio of males (All) and females (All) to the total (total confirmed covid positive cases). How many females were in the unknown age category (rounded to nearest integer)?

- Options**
- A. 120
  - B. 140
  - C. 110
  - D. 125
  - E. 130

Question ID : 41569989  
 Status : Answered  
 Chosen Option : D

**Comprehension:**

**Go through the information given below, and answer the THREE questions that follow.**

The table captures *Age* and *Gender* distribution of Covid Positive Cases in a country. However, a part of data is missing, represented through unknown categories.

		<i>Total Confirmed Covid Positive Cases</i>	<b>Gender</b>		
			<i>Female</i>	<i>Male</i>	<i>Unknown</i>
<b>Age</b>	<i>All</i>	117,586*	62,434	53,825	1,327
	<i>Unknown</i>	235			
	<i>0-18</i>	22,362	11,147	10,880	
	<i>19-30</i>	32,860	18,768	13,743	
	<i>31-40</i>	24,110	12,693	11,118	
	<i>41-50</i>	14,120	7,264	6,688	
	<i>51-60</i>	11,174	5,567	5,523	
	<i>61-70</i>	7,300	3,756	3,513	
	<i>71-80</i>	3,429	1,875	1,534	
	<i>81+</i>	1,996	1,276	708	

\*Includes <5 cases in age group 19-30 and 51-60 who reported gender as Other/Transgender.  
\* In unknown age category, the ratio of males (unknown age category) and females (unknown age category) to total unknown cases (unknown age category) is same as the ratio of males (All) and females (All) to the total (Total Confirmed Covid Positive Cases).

**SubQuestion No : 75**

**Q.75 In which age category, the percentage of female covid patients is the HIGHEST?**

- Options**
- A. 61-70
  - B. 31-40
  - C. 41-50
  - D. 51-60
  - E. 81+

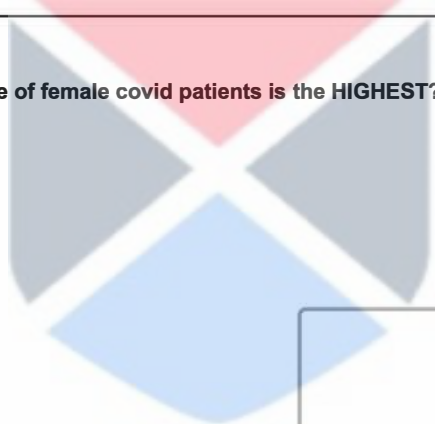

Question ID : 41569990  
Status : Answered  
Chosen Option : D

**Comprehension:**

Go through the information given below, and answer the THREE questions that follow.

The table captures *Age* and *Gender* distribution of Covid Positive Cases in a country. However, a part of data is missing, represented through unknown categories.

		<b>Gender</b>			
		<i>Total Confirmed Covid Positive Cases</i>	<i>Female</i>	<i>Male</i>	<i>Unknown</i>
<b>Age</b>	<i>All</i>	117,586*	62,434	53,825	1,327
	<i>Unknown</i>	235			
	<i>0-18</i>	22,362	11,147	10,880	
	<i>19-30</i>	32,860	18,768	13,743	
	<i>31-40</i>	24,110	12,693	11,118	
	<i>41-50</i>	14,120	7,264	6,688	
	<i>51-60</i>	11,174	5,567	5,523	
	<i>61-70</i>	7,300	3,756	3,513	
	<i>71-80</i>	3,429	1,875	1,534	
	<i>81+</i>	1,996	1,276	708	

\*Includes <5 cases in age group 19-30 and 51-60 who reported gender as Other/Transgender.  
\* In unknown age category, the ratio of males (unknown age category) and females (unknown age category) to total unknown cases (unknown age category) is same as the ratio of males (All) and females (All) to the total (Total Confirmed Covid Positive Cases).

**SubQuestion No : 76**

**Q.76 Which of the following is true for “unknown gender Category”?**

1. Unknown age group patients are less likely (percentage term) to provide information about gender than any other age category
2. Between 31 and 80, when age increases patients, in percentage terms, are less likely to provide information about gender
3. Elderly (81+) category patients are more likely to give information about gender than 0-18 age group

- Options**
- A. 3 only
  - B. 2 only
  - C. 1 and 2
  - D. 1 and 3
  - E. 2 and 3

Question ID : 41569991  
Status : Answered  
Chosen Option : A



Q.1

Please type following sentence and symbols

"The quick brown fox jumps over the lazy dog."

`(?;!;%:/)'

Given "The quick brown fox jumps over the lazy dog."

Answer : `(?;!;%:/)'

Question ID : 41569992

Status : Answered

Section : General Knowledge

Q.1 Which price index is being used to measure inflation by the Reserve Bank of India?

- Options
- A. Purchasing Power Parity based Index
  - B. Wholesale Price Index
  - C. Industrial Cost and Price Indices
  - D. GDP Deflator
  - E. Consumer Price Index

Question ID : 415699100

Status : Answered

Chosen Option : E

Q.2 Which institution published the cartoon book titled Raju & The Forty Thieves – A Booklet on Modus Operandi of Financial Fraudsters?

- Options
- A. The Ministry of Finance, Government of India
  - B. The State Bank of India
  - C. The Punjab National Bank
  - D. The Reserve Bank of India
  - E. The Ministry of Corporate Affairs, Government of India

Question ID : 41569999

Status : Answered

Chosen Option : D

Q.3 Which company developed Vikram-S, India's first private space rocket, that was launched from Satish Dhawan Space Centre in Sriharikota on November 18, 2022?

- Options
- A. Skyroot Aerospace
  - B. Brahmos Aerospace Private Limited
  - C. Lockheed Martin India Private Limited
  - D. Indian Rotorcraft
  - E. Mahindra Aerospace

Question ID : 41569998

Status : Answered

Chosen Option : A

**Q.4 Who has been appointed as the Chief Justice of India in November 2022?**

- Options**
- A. Justice N. V. Ramana
  - B. Justice U. U. Lalit
  - C. Justice Yashwant (Y.V.) Chandrachud
  - D. Justice Dhananjay (D.Y) Chandrachud
  - E. Justice S.J. Mukhopadhaya

Question ID : **415699107**  
Status : **Answered**  
Chosen Option : **D**

**Q.5 Match the famous CEOs with the title of their biographies.**

A. Indra Nooyi	1. Zero to one
B. Gregory Zuckerman	2. The man who solved the market
C. Peter Thiel	3. My life in Full: work Family and our future
D. Sheryl Sandberg	4. Lean In: Women work and will to lead

- Options**
- A. A4, B3, C1, D2
  - B. A1, B2, C3, D4
  - C. A2, B1, C4, D3
  - D. A3, B2, C1, D4
  - E. A1, B3, C4, D2

Question ID : **415699104**  
Status : **Answered**  
Chosen Option : **D**

**Q.6 The first ever Wildlife conservation bond (a financial instrument) in the world, was floated to conserve which of the following critically endangered species?**

- Options**
- A. Cheetah in India
  - B. Water Buffalo in Africa
  - C. Giant Panda in China
  - D. Black Rhino in South Africa
  - E. Opossum in Australia

Question ID : **415699103**  
Status : **Answered**  
Chosen Option : **B**

**Q.7 Which of the following is the world's largest River delta?**

- Options**
- A. The Ganges River delta
  - B. The Amazon River delta
  - C. The Mississippi River delta
  - D. The Nile River delta
  - E. The Mekong River delta

Question ID : **41569993**  
Status : **Answered**  
Chosen Option : **B**

**Q.8 Which organization, in October 2022, imposed a penalty on Alphabet for violating anti-trust laws in India?**

- Options**
- A. Supreme Court of India
  - B. Government of India
  - C. Niti Aayog
  - D. Competition Commission of India
  - E. Monopolies and Restrictive Trade Practices

Question ID : **415699115**  
Status : **Answered**  
Chosen Option : **D**

**Q.9 Which of the following is the right description of INS-Arihant?**

- Options**
- A. Corvette
  - B. Aircraft Carrier
  - C. Frigate
  - D. Nuclear powered Submarine
  - E. Destroyer

Question ID : **415699113**  
Status : **Answered**  
Chosen Option : **B**

**Q.10 Which of the following was NOT a reason associated with Sri Lankan economic crisis of 2022?**

- Options**
- A. Decline of tourist inflow
  - B. Decline in FOREX reserves
  - C. COVID-19
  - D. Shift towards organic agriculture
  - E. Decline of fisheries

Question ID : **415699116**  
Status : **Answered**  
Chosen Option : **E**

**Q.11 From the following, choose the Article in the Constitution of India that proclaims: "It shall be the obligation of every citizen of India to safeguard and develop the natural environment, including forests, lakes, rivers, and animals, and to have compassion for living beings."**

- Options**
- A. Article 14A
  - B. Article (13b)
  - C. Article 51A (g)
  - D. Article 15
  - E. Article 21

Question ID : **41569996**  
Status : **Answered**  
Chosen Option : **E**

**Q.12** BTS (Bangtan Boys), the pop-music band, belongs to which country?

- Options**
- A. India
  - B. South Korea
  - C. USA
  - D. UK
  - E. Australia

Question ID : **415699105**  
Status : **Answered**  
Chosen Option : **B**

**Q.13** Match the following animals/birds with the Wildlife Sanctuary, National Park or a region that they naturally occur.

A. Great Indian bustard	1. Manas National Park
B. Megapode	2. Sri Lankamalleswara Wildlife Sanctuary
C. Jerdon's Courser	3. Desert National Park
D. Pigmy Hog	4. Nicobar Island Sanctuary

- Options**
- A. A2, B3, C4, D1
  - B. A2, B4, C1, D3
  - C. A1, B4, C3, D2
  - D. A4, B3, C1, D2
  - E. A3, B4, C2, D1

Question ID : **415699112**  
Status : **Answered**  
Chosen Option : **B**

**Q.14** Which former Prime Minister of India wrote "Kaidi Kavirai Ki Kundalian," a poetic compilation, while being lodged in jail?

- Options**
- A. I.K. Gujral
  - B. Lal Bahadur Shastri
  - C. Chandra Shekhar
  - D. Jawaharlal Nehru
  - E. Atal Bihari Vajpayee

Question ID : **41569994**  
Status : **Answered**  
Chosen Option : **B**

**Q.15** Which of the following is not a site associated with the Indus Valley Civilization?

- Options**
- A. Bhimbetka
  - B. Mohenjo-Daro
  - C. Lothal
  - D. Ropar
  - E. Harappa

Question ID : **415699111**  
Status : **Answered**  
Chosen Option : **D**

**Q.16 Which of the following breakthrough decisions was taken at the COP 27 (8-20 Nov 2022, Sharm el-Sheikh, Egypt)?**

- Options**
- A. Establish and operationalize a “global early warning system” for weather events
  - B. Establish and operationalize a “global ecosystem services payments mechanism”
  - C. Establish and operationalize a “loss and damage” fund
  - D. Accept and operationalize a “global carbon tax and trading mechanism”
  - E. Accept and operationalize a “Net zero” target for every country

Question ID : **41569997**  
Status : **Answered**  
Chosen Option : **C**

**Q.17 Who of the following is not a Gig worker?**

- Options**
- A. Uber driver
  - B. Plumber on call
  - C. Freelance worker
  - D. Zomato delivery Boy
  - E. Person running a salon

Question ID : **415699110**  
Status : **Answered**  
Chosen Option : **E**

**Q.18 Match the new names of the given companies with their respective old names.**

Old Name	New Name
A. Google	1. Altria
B. Facebook	2. Alphabet
C. Phillippe Morris	3. Meta
D. McAfee	4. Intel Security

- Options**
- A. A2, B3, C1, D4
  - B. A2, B1, C4, D3
  - C. A1, B2, C3, D4
  - D. A1 B3, C4, D2
  - E. A3, B2, C1, D4

Question ID : **415699109**  
Status : **Answered**  
Chosen Option : **A**

**Q.19 Who scored the maximum number of goals in the recently concluded FIFA world cup, 2022?**

- Options**
- A. Marcus Rashford
  - B. Neymar da Silva Santos Junior
  - C. Lionel Messi
  - D. Kylien Mbappe
  - E. Olivier Giroud

Question ID : **415699117**  
Status : **Answered**  
Chosen Option : **D**

**Q.20 Identify the sectors into which the Indian economy is divided, for the calculation of GDP?**

- Options**
- A. Agriculture, Manufacturing and E-commerce
  - B. Primary and non-primary
  - C. Agriculture, Defence, Information Technology and Manufacturing
  - D. Government, Private and Social
  - E. Agriculture, Manufacturing and Services

Question ID : **415699101**  
Status : **Answered**  
Chosen Option : **E**

**Q.21 Which of the following animals are on the State Emblem of India?**

- Options**
- A. Lion, Elephant, and Horse
  - B. Lion, Bull, and Elephant
  - C. Lion, Bull, and Horse
  - D. Lion, Tiger, and Cow
  - E. Lion, Tiger, and Bull

Question ID : **41569995**  
Status : **Answered**  
Chosen Option : **B**

**Q.22 Match the United Nation's Secretary Generals with their citizenships, at the time of appointment.**

A. Kurt Waldheim	1. Austria
B. Kofi Annan	2. South Korea
C. Antonio Guterres	3. Portugal
D. Ban Ki Moon	4. Ghana

- Options**
- A. A2, B3, C4, D1
  - B. A4, B3, C1, D2
  - C. A1, B4, C3, D2
  - D. A2, B4, C1, D3
  - E. A1, B4, C2, D3

Question ID : **415699114**  
Status : **Answered**  
Chosen Option : **C**

**Q.23 Which of the following is NOT attributed as a reason for Russian invasion of Ukraine?**

- Options**
- A. Ukraine's refusal to export wheat to Russia
  - B. Ukraine has citizens of different ethnicities
  - C. NATO's expansion into East Europe and Ukraine
  - D. Russia fears that Ukraine, with the support of NATO, will claim back Crimea
  - E. Saving people of Russian origin in the eastern region of Ukraine

Question ID : **415699106**  
Status : **Answered**  
Chosen Option : **A**

**Q.24 Which of the following countries did not qualify for FIFA World Cup Qatar 2022?**

- Options**
- A. Morocco
  - B. Senegal
  - C. Switzerland
  - D. Italy
  - E. Australia

Question ID : **415699108**  
Status : **Answered**  
Chosen Option : **D**

**Q.25 Which institution was renamed as "Niti Aayog"?**

- Options**
- A. Government Policy Commission
  - B. Infrastructural and Development Commission
  - C. Planning Commission of India
  - D. Economic Planning Council
  - E. Policy Aayog of India

Question ID : **415699102**  
Status : **Answered**  
Chosen Option : **A**

Section : **ESSAY**

**Q.26 Choose ONE of the three arguments given below and develop a coherent essay that critically evaluates it. Support your analysis with relevant claims, reasons and/or examples. The essay should not exceed 250 words.**

**Argument I. Risk is the essential need of soul. The absence of risk produces a kind of boredom which paralyses in a different way from fear, but almost as much.**

**Argument II. Rapid decarbonization to fulfill India's Net Zero commitment will have business consequences.**

**Argument III. Someone with half your IQ is making 10X as you because they aren't smart enough to doubt themselves.**

**Answer Question no. 26 if you choose Argument I.**

**Answer Question no. 27 if you choose Argument II.**

**Answer Question no. 28 if you choose Argument III.**

Given --  
Answer :

Question ID : **415699118**  
Status : **Not Answered**

**Q.27 Argument II. Rapid decarbonization to fulfill India's Net Zero commitment will have business consequences.**

Given --  
Answer :

Question ID : **415699119**  
Status : **Not Answered**

**Q.28** Argument III. Someone with half your IQ is making 10X as you because they aren't smart enough to doubt themselves.

Given **Well-begun is half done. We have heard this over the years but how many of us**  
Answer : **actually have the courage to begin, at all? How many of us can shed that doubt?**  
**We have now entered the year 2023 and it is a shame that in a country as vast and diverse as India, we still measure a person's intelligence quotient (or IQ) based on their level of education. Or their alma mater. Or the choice of degree they choose to pursue. How much further will we keep digging? And why do we judge someone based only on a sheet of paper? There are several other factors that go into deciding a person's IQ rather than the stream they choose or the entrance examination they crack (or not). Today, we see people with half the IQ than that of someone from a top notch college making 10 times or even more. We see many examples. There are Product Managers who studied from tier-3 colleges at companies with an annual revenue of more than 150 crore INR, who never had a fancy tech or MBA degree, earning more than those with the same. There are entrepreneurs without any formal training building great products and services. There is a self-titled MBA Chai Wala earning more than MBA grads from the top B-Schools in the country. And you know what they all have in common?. Courage. Courage to take risks, to face failure, to not doubt themselves. There is a saying in Hindi which roughly translates to "the loser is the one who never fought." And why does one not fight? Because they doubt themselves and their capabilities. And that is where they lose the game before it has even begun.**

Question ID : 415699120

Status : Answered

