

MHT CET 2nd and 3rd May 2019

Test Date	02/05/2019
Test Time	2:00 PM - 5:00 PM
Subject	PCM

Section : Physics

Q.1 A metal surface is illuminated by light of given intensity and frequency to cause photoemission. If the intensity of illumination is reduced to one fourth of its original value then the maximum K.E. of the emitted photoelectrons would be

- Ans
- 1. twice the original value.
 - 2. four times the original value.
 - 3. one fourth of the original value.
 - 4. unchanged.

Question Type : MCQ

Question ID : 588552796

Option 1 ID : 5885523183

Option 2 ID : 5885523184

Option 3 ID : 5885523182

Option 4 ID : 5885523181

Status : Answered

Chosen Option : 4

Q.2 Torque acting on a rectangular coil carrying current 'I' situated parallel to magnetic field of induction 'B', having number of turns 'n' and area 'A' is

- Ans
- 1. $nI(\hat{A} \cdot \hat{B})$
 - 2. $\frac{nBA}{I}$
 - 3. $nI(\vec{A} \times \vec{B})$
 - 4. $\frac{IBA}{n}$

Question Type : MCQ

Question ID : 588552781

Option 1 ID : 5885523122

Option 2 ID : 5885523124

Option 3 ID : 5885523121

Option 4 ID : 5885523123

Status : Answered

Chosen Option : 3

Q.3

A force $(\vec{F}) = -5\hat{i} - 7\hat{j} + 3\hat{k}$ acting on a particle causes a displacement $(\vec{s}) = 3\hat{i} - 2\hat{j} + a\hat{k}$ in its own direction. If the work done is 14 J, then the value of 'a' is

- Ans
- 1. 0
 - 2. 5
 - 3. 15
 - 4. 1

Question Type : MCQ

Question ID : 588552797

Option 1 ID : 5885523188

Option 2 ID : 5885523186

Option 3 ID : 5885523185

Option 4 ID : 5885523187

Status : Answered

Chosen Option : 2

Q.4 When the electron in hydrogen atom jumps from fourth Bohr orbit to second Bohr orbit, one gets the

- Ans
- 1. second line of Balmer series.
 - 2. first line of Balmer series.
 - 3. first line of Pfund series.
 - 4. second line of Paschen series.

Question Type : MCQ

Question ID : 588552790

Option 1 ID : 5885523158

Option 2 ID : 5885523160

Option 3 ID : 5885523159

Option 4 ID : 5885523157

Status : Answered

Chosen Option : 1

Q.5 Light of wavelength ' λ ' is incident on a single slit of width 'a' and the distance between slit and screen is 'D'. In diffraction pattern, if slit width is equal to the width of the central maximum then 'D' is equal to

- Ans
- 1. $a / 2\lambda$
 - 2. $a^2 / 2\lambda$
 - 3. a / λ
 - 4. a^2 / λ

Question Type : MCQ

Question ID : 588552789

Option 1 ID : 5885523154

Option 2 ID : 5885523153

Option 3 ID : 5885523156

Option 4 ID : 5885523155

Status : Answered

Chosen Option : 2

Q.6 In U. C. M., when time interval $\delta t \rightarrow 0$, the angle between change in velocity ($\delta\vec{v}$) and linear velocity (\vec{v}) will be

- Ans
- 1. 0°

✓ 2. 90°

✗ 3. 180°

✗ 4. 45°

Question Type : MCQ

Question ID : 588552760

Option 1 ID : 5885523037

Option 2 ID : 5885523039

Option 3 ID : 5885523040

Option 4 ID : 5885523038

Status : Answered

Chosen Option : 2

Q.7 A stretched string fixed at both ends has 'm' nodes, then the length of the string will be

Ans

✓ 1. $(m - 1) \frac{\lambda}{2}$

✗ 2. $\frac{(m + 1)\lambda}{2}$

✗ 3. $\frac{m\lambda}{2}$

✗ 4. $(m - 2) \frac{\lambda}{2}$

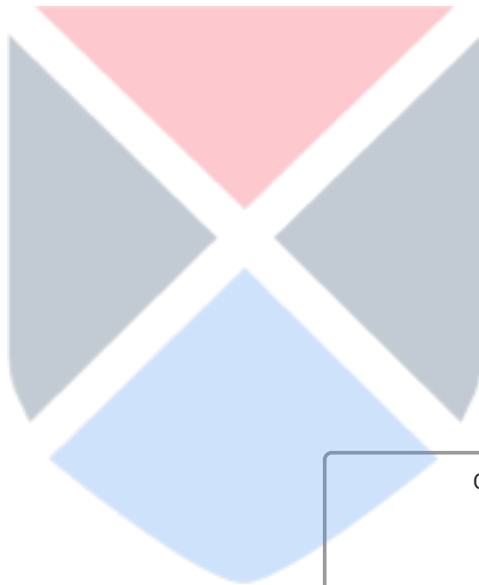

Question Type : MCQ

Question ID : 588552778

Option 1 ID : 5885523109

Option 2 ID : 5885523112

Option 3 ID : 5885523111

Option 4 ID : 5885523110

Status : Answered

Chosen Option : 2

Q.8 A particle is performing a linear simple harmonic motion of amplitude 'A'. When it is midway between its mean and extreme position, the magnitudes of its velocity and acceleration are equal. What is the periodic time of the motion?

Ans

✓ 1. $\frac{2\pi}{\sqrt{3}} s$

✗ 2. $\frac{\sqrt{3}}{2\pi} s$

✗ 3. $2\pi \sqrt{3} s$

4. $\frac{1}{2\pi\sqrt{3}} \text{ s}$

Question Type : MCQ

Question ID : 588552774

Option 1 ID : 5885523093

Option 2 ID : 5885523094

Option 3 ID : 5885523096

Option 4 ID : 5885523095

Status : Answered

Chosen Option : 1

Q.9 Three identical rods each of mass 'M' and length 'L' are joined to form a symbol 'H'. The moment of inertia of the system about one of the sides of 'H' is

Ans

1. $2 ML^2/3$

2. $ML^2/2$

3. $ML^2/6$

4. $4 ML^2/3$

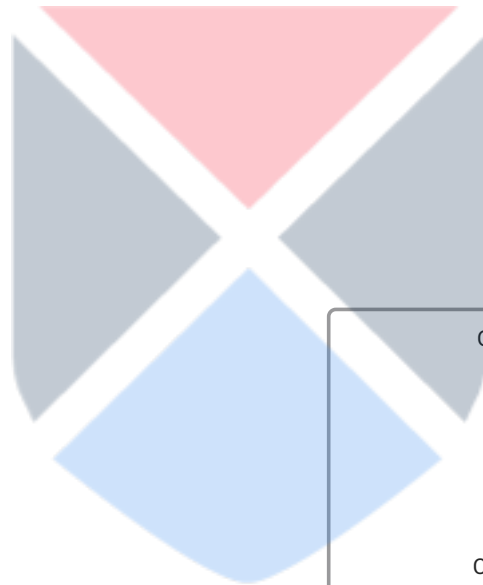

Question Type : MCQ

Question ID : 588552769

Option 1 ID : 5885523074

Option 2 ID : 5885523075

Option 3 ID : 5885523076

Option 4 ID : 5885523073

Status : Answered

Chosen Option : 4

Q.1 The luminous border that surrounds the profile of a mountain just before sun rises behind it, is an example of

Ans

1. dispersion.

2. total internal reflection.

3. interference.

4. diffraction.

Question Type : MCQ

Question ID : 588552751

Option 1 ID : 5885523002

Option 2 ID : 5885523003

Option 3 ID : 5885523001

Option 4 ID : 5885523004

Status : Answered

Chosen Option : 4

Q.1 A block of mass 'm' moving on a frictionless surface at speed 'v' collides elastically with a block of same mass, initially at rest. Now the first block moves at an angle 'θ' with its initial

direction and has speed ' V_1 '. The speed of the second block after collision is

Ans

1. $\sqrt{V_1^2 - V^2}$

2. $\sqrt{V^2 - V_1^2}$

3. $\sqrt{V^2 + V_1^2}$

4. $\sqrt{V - V_1}$

Question Type : MCQ

Question ID : 588552799

Option 1 ID : 5885523194

Option 2 ID : 5885523193

Option 3 ID : 5885523195

Option 4 ID : 5885523196

Status : Answered

Chosen Option : 2

Q.1
2 Three point masses each of mass ' m ' are kept at the corners of an equilateral triangle of side ' L '. The system rotates about the center of the triangle without any change in the separation of masses during rotation. The period of rotation is directly proportional to ($\cos 30^\circ = \sin 60^\circ = \sqrt{3}/2$)

Ans

1. \sqrt{L}

2. $L^{3/2}$

3. L

4. L^{-2}

Question Type : MCQ

Question ID : 588552766

Option 1 ID : 5885523064

Option 2 ID : 5885523061

Option 3 ID : 5885523063

Option 4 ID : 5885523062

Status : Answered

Chosen Option : 2

Q.1 Two pendulums begin to swing simultaneously. The first pendulum makes nine full
3 oscillations when the other makes seven. The ratio of the lengths of the two pendulums is

Ans



1.

$$\frac{49}{81}$$



2.

$$\frac{64}{81}$$



3.

$$\frac{8}{9}$$



4.

$$\frac{7}{9}$$

Question Type : MCQ

Question ID : 588552788

Option 1 ID : 5885523151

Option 2 ID : 5885523152

Option 3 ID : 5885523150

Option 4 ID : 5885523149

Status : Answered

Chosen Option : 1

Q.1 When light enters glass from vacuum, then the wavelength of light

4

Ans



1. decreases.



2. becomes zero.



3. remains same.



4. increases.

Question Type : MCQ

Question ID : 588552786

Option 1 ID : 5885523142

Option 2 ID : 5885523143

Option 3 ID : 5885523144

Option 4 ID : 5885523141

Status : Answered

Chosen Option : 1

Q.1 Which one of the following statement is correct ?

5

Ans



1. Surface energy is potential energy per unit length.



2. Surface tension is work done per unit area.



3. Surface tension is work done per unit length.



4. Surface energy is work done per unit force.

Question Type : MCQ

Question ID : 588552773

Option 1 ID : 5885523092

Option 2 ID : 5885523090

Option 3 ID : 5885523089
Option 4 ID : 5885523091
Status : Answered
Chosen Option : 2

Q.1 What is the minimum energy required to launch a satellite of mass 'm' from the surface of the
6 earth of mass 'M' and radius 'R' at an altitude 2 R?

Ans

1. $\frac{GMm}{2R}$

2. $\frac{2GMm}{3R}$

3. $\frac{GMm}{3R}$

4. $\frac{5GMm}{6R}$

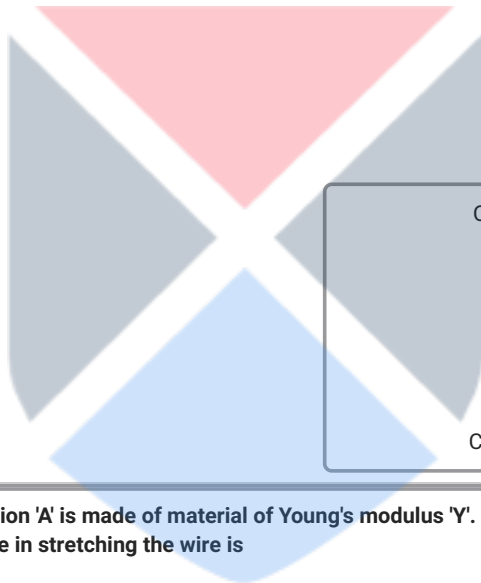

Question Type : MCQ
Question ID : 588552800
Option 1 ID : 5885523197
Option 2 ID : 5885523200
Option 3 ID : 5885523198
Option 4 ID : 5885523199
Status : Answered
Chosen Option : 2

Q.1 A wire of length 'L' and area of cross section 'A' is made of material of Young's modulus 'Y'. It is
7 stretched by an amount 'x' The work done in stretching the wire is

Ans

1. $\frac{Yx^2A}{2L}$

2. $\frac{2Yx^2A}{L}$

3. $\frac{YxA}{2L}$

4. $\frac{Yx^2A}{2}$

Question Type : MCQ

Question ID : 588552767

Option 1 ID : 5885523067

Option 2 ID : 5885523068

Option 3 ID : 5885523065

Option 4 ID : 5885523066

Status : Answered

Chosen Option : 1

Q.1 In a parallel plate air capacitor the distance between plates is reduced to one fourth and the space between them is filled with a dielectric medium of constant 2. If the initial capacity of the capacitor is $4\mu\text{F}$, then its new capacity is

Ans 1. $32\mu\text{F}$

2. $18\mu\text{F}$

3. $8\mu\text{F}$

4. $44\mu\text{F}$

Question Type : MCQ

Question ID : 588552793

Option 1 ID : 5885523171

Option 2 ID : 5885523170

Option 3 ID : 5885523169

Option 4 ID : 5885523172

Status : Answered

Chosen Option : 1

Q.1 An aircraft is moving with uniform velocity 150 m/s in the space. If all the forces acting on it are balanced, then it will

Ans 1. keep moving with same velocity.

2. remain floating at its place.

3. escape in space.

4. fall down on earth.

Question Type : MCQ

Question ID : 588552795

Option 1 ID : 5885523177

Option 2 ID : 5885523180

Option 3 ID : 5885523179

Option 4 ID : 5885523178

Status : Answered

Chosen Option : 1

Q.2 In case of p-n junction diode, the width of depletion region is

Ans 1. decreased with heavy doping.

2. increased by reverse biasing.

3. decreased with light doping.

4. increased by forward biasing.

Question Type : MCQ

Question ID : 588552783

Option 1 ID : 5885523130

Option 2 ID : 5885523129

Option 3 ID : 5885523131

Option 4 ID : 5885523132
Status : Answered
Chosen Option : 2

Q.2 In the study of transistor as an amplifier, the ratio of collector current to emitter current is 1 0.98 then the ratio of collector current to base current will be

- Ans
- 1. 99
 - 2. 49
 - 3. 50
 - 4. 98

Question Type : MCQ
Question ID : 588552764
Option 1 ID : 5885523056
Option 2 ID : 5885523053
Option 3 ID : 5885523054
Option 4 ID : 5885523055
Status : Answered
Chosen Option : 2

Q.2 A stretched wire of length 260 cm is set into vibrations. It is divided into three segments 2 whose frequencies are in the ratio 2:3:4. Their lengths must be

- Ans
- 1. 80 cm, 60 cm, 120 cm
 - 2. 120 cm, 80 cm, 60 cm
 - 3. 60 cm, 80 cm, 120 cm
 - 4. 120 cm, 60 cm, 80 cm

Question Type : MCQ
Question ID : 588552755
Option 1 ID : 5885523020
Option 2 ID : 5885523017
Option 3 ID : 5885523018
Option 4 ID : 5885523019
Status : Answered
Chosen Option : 2

Q.2
3 The force 'F' acting on a body of density 'd' are related by the relation $F = \frac{y}{\sqrt{d}}$. The dimensions of 'y' are

- Ans
- 1. $[L^{-\frac{1}{2}} M^{\frac{3}{2}} T^{-2}]$
 - 2. $[L^{-1} M^{\frac{1}{2}} T^{-2}]$
 - 3. $[L^{-1} M^{\frac{3}{2}} T^{-2}]$
 - 4. $[L^{-\frac{1}{2}} M^{\frac{1}{2}} T^{-2}]$

Question Type : MCQ
Question ID : 588552756

Option 1 ID : 5885523022
Option 2 ID : 5885523024
Option 3 ID : 5885523023
Option 4 ID : 5885523021
Status : Answered
Chosen Option : 1

Q.2 The magnetization of bar magnet of length 5 cm, cross sectional area 2 cm^2 and net magnetic moment 1 Am^2 is

- Ans
- 1. $3 \times 10^5 \text{ A/m}$
 - 2. $4 \times 10^5 \text{ A/m}$
 - 3. $2 \times 10^5 \text{ A/m}$
 - 4. $1 \times 10^5 \text{ A/m}$

Question Type : MCQ
Question ID : 588552770
Option 1 ID : 5885523079
Option 2 ID : 5885523080
Option 3 ID : 5885523078
Option 4 ID : 5885523077
Status : Answered
Chosen Option : 4

Q.2 The dimensions of self or mutual inductance are given as

- Ans
- 1. $[L^{-2}M^1T^{-2}I^{-2}]$
 - 2. $[L^2M^2T^{-2}I^{-2}]$
 - 3. $[L^2M^1T^{-2}I^{-2}]$
 - 4. $[L^2M^2T^{-2}I^{-1}]$

Question Type : MCQ
Question ID : 588552785
Option 1 ID : 5885523140
Option 2 ID : 5885523137
Option 3 ID : 5885523138
Option 4 ID : 5885523139
Status : Answered
Chosen Option : 3

Q.2 Which of the following molecules is a polar molecule ?

Ans

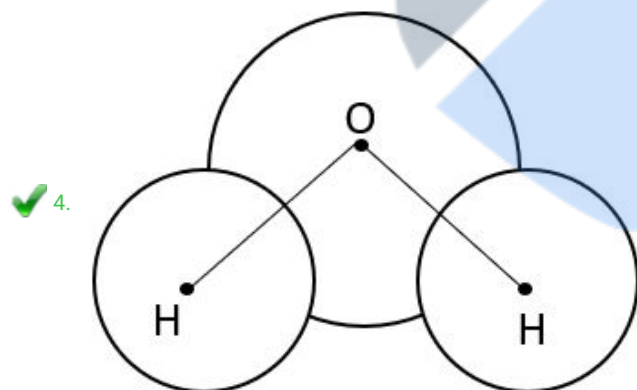
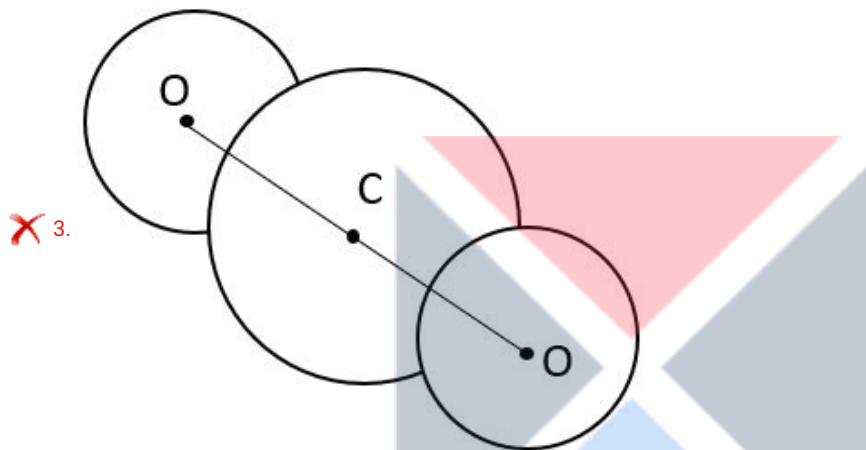
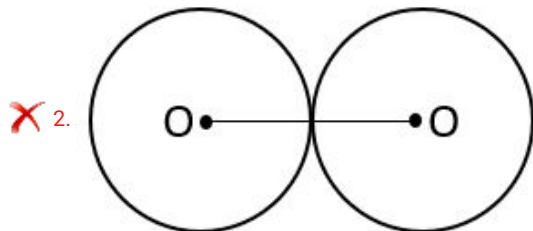
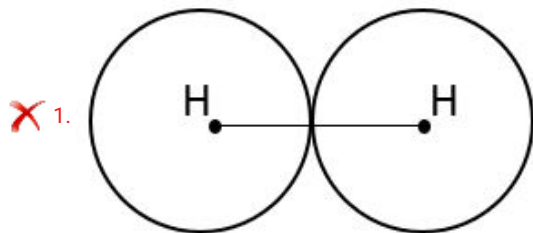

Question Type : MCQ

Question ID : 588552762

Option 1 ID : 5885523045

Option 2 ID : 5885523048

Option 3 ID : 5885523046

Option 4 ID : 5885523047

Status : Answered

Chosen Option : 4

Q.2 Magnetic susceptibility of a paramagnetic substance is

7

Ans ✗ 1. large and positive.

✓ 2. small and positive.

3. small and negative.

4. large and negative.

Question Type : MCQ

Question ID : 588552791

Option 1 ID : 5885523163

Option 2 ID : 5885523161

Option 3 ID : 5885523162

Option 4 ID : 5885523164

Status : Answered

Chosen Option : 2

Q.2 A circular coil of wire consisting of 100 turns each of radius 9 cm carries a current of 0.4 A.

8 The magnitude of the magnetic field at the centre of coil is [$\mu_0 = 12.56 \times 10^{-7}$ S.I. Unit]

Ans 1. 2.4×10^{-11} T

2. 2.79×10^{-5} T

3. 2.79×10^{-4} T

4. 2.79×10^{-3} T

Question Type : MCQ

Question ID : 588552780

Option 1 ID : 5885523117

Option 2 ID : 5885523118

Option 3 ID : 5885523119

Option 4 ID : 5885523120

Status : Answered

Chosen Option : 3

Q.2 A simple harmonic progressive wave is represented as $y = 0.03 \sin \pi (2t - 0.01x)$ m.

9 At a given instant of time, the phase difference between two particles 25 m apart is

Ans 1. π rad

2. $\frac{\pi}{2}$ rad

3. $\frac{\pi}{4}$ rad

4. $\frac{\pi}{8}$ rad

Question Type : MCQ

Question ID : 588552768

Option 1 ID : 5885523072

Option 2 ID : 5885523071

Option 3 ID : 5885523070

Option 4 ID : 5885523069

Status : Answered

Chosen Option : 3

Q.3 The equation of state for 2g of oxygen at a pressure 'P' and temperature 'T', when occupying a volume 'V' will be

Ans 1. $PV = 16 RT$

2. $PV=RT$

3. $PV = \frac{1}{16} RT$

4. $PV = 2RT$

Question Type : MCQ

Question ID : 588552757

Option 1 ID : 5885523027

Option 2 ID : 5885523026

Option 3 ID : 5885523025

Option 4 ID : 5885523028

Status : Answered

Chosen Option : 3

Q.3 The magnetic dipole moment of a short magnetic dipole at a distant point along the equator of magnet has a magnitude of 'X' in S.I. units. If the distance between the point and the magnet is halved then the magnitude of dipole moment will be

Ans 1. $2 X$

2. $\frac{1}{2} X$

3. X

4. $\frac{1}{8} X$

Question Type : MCQ

Question ID : 588552792

Option 1 ID : 5885523168

Option 2 ID : 5885523166

Option 3 ID : 5885523167

Option 4 ID : 5885523165

Status : Answered

Chosen Option : 3

Q.3 The ratio of the dimensions of Planck's constant to that of moment of inertia is the dimensions of

Ans 1. angular momentum.

2. velocity.

3. frequency.

4. time.

Question Type : MCQ

Question ID : 588552777

Option 1 ID : 5885523106
Option 2 ID : 5885523105
Option 3 ID : 5885523108
Option 4 ID : 5885523107
Status : Answered
Chosen Option : 3

Q.3 If 'x', 'V' and 'a' denote the displacement, velocity and acceleration of a particle respectively
3 executing S.H.M. of periodic time 'T', then which one of the following does not change with time?

Ans

✓ 1. $\frac{aT}{x}$

✗ 2. $at + 2\pi V$

✗ 3. $\frac{aT}{V}$

✗ 4. $aT + 4\pi^2 V^2$

Question Type : MCQ
Question ID : 588552759
Option 1 ID : 5885523034
Option 2 ID : 5885523035
Option 3 ID : 5885523036
Option 4 ID : 5885523033
Status : Answered
Chosen Option : 1

Q.3 A particle is performing U.C.M. along the circumference of a circle of diameter 50 cm with
4 frequency 2 Hz. The acceleration of the particle in m/s^2 is

Ans

✗ 1. $2\pi^2$

✗ 2. $8\pi^2$

✗ 3. π^2

✓ 4. $4\pi^2$

Question Type : MCQ
Question ID : 588552784
Option 1 ID : 5885523135
Option 2 ID : 5885523133
Option 3 ID : 5885523136
Option 4 ID : 5885523134

Status : Answered
Chosen Option : 4

Q.3 Find the wrong statement from the following about the equation of stationary wave given by $y = 0.04 \cos(\pi x) \sin(50\pi t)$ m where t is in second. Then for the stationary wave.

- Ans
- 1. Time period = 0.02 s
 - 2. Wavelength = 2 m
 - 3. Velocity = 50 m/s
 - 4. Amplitude = 0.02 m

Question Type : MCQ
Question ID : 588552782
Option 1 ID : 5885523127
Option 2 ID : 5885523126
Option 3 ID : 5885523128
Option 4 ID : 5885523125
Status : Marked For Review
Chosen Option : 1

Q.3 A convex lens of focal length 'f' is placed in contact with a concave lens of the same focal length. The equivalent focal length of the combination is

- Ans
- 1. f
 - 2. infinity
 - 3. f/2
 - 4. zero

Question Type : MCQ
Question ID : 588552776
Option 1 ID : 5885523103
Option 2 ID : 5885523104
Option 3 ID : 5885523102
Option 4 ID : 5885523101
Status : Answered
Chosen Option : 2

Q.3 Two light balls are suspended as shown in figure . When a stream of air passes through the space between them, the distance between the balls will

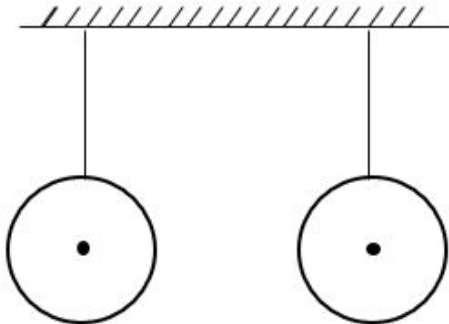

- Ans
- 1. remain same.
 - 2. increase.
 - 3. may increase or decrease, depending on speed of air.
 - 4. decrease.

Question Type : MCQ

Question ID : 588552765
Option 1 ID : 5885523059
Option 2 ID : 5885523058
Option 3 ID : 5885523060
Option 4 ID : 5885523057
Status : **Marked For Review**
Chosen Option : 4

Q.3 The range of an ammeter of resistance 'G' can be increased from 'I' to 'nI' by connecting

8

Ans

1. a series resistance of $\frac{G}{n-1} \Omega$

2. a shunt of $\frac{G}{n-1} \Omega$

3. a shunt of $\frac{G}{n+1} \Omega$

4. a series resistance of $\frac{G}{n+1} \Omega$

Question Type : **MCQ**
Question ID : 588552758
Option 1 ID : 5885523032
Option 2 ID : 5885523031
Option 3 ID : 5885523029
Option 4 ID : 5885523030
Status : **Answered**
Chosen Option : 2

Q.3 The critical angle for light going from medium 'x' to medium 'y' is ' θ '. The speed of light in medium 'x' is ' V_x '. The speed of light in medium 'y' is

9

Ans

1. $V_x / \tan \theta$

2. $V_x \sin \theta$

3. $V_x \tan \theta$

4. $V_x / \sin \theta$

Question Type : **MCQ**
Question ID : 588552752
Option 1 ID : 5885523008
Option 2 ID : 5885523006
Option 3 ID : 5885523007
Option 4 ID : 5885523005
Status : **Answered**
Chosen Option : 4

Q.4 When a 12000 joule of work is done on a flywheel, its frequency of rotation increases from 10
0 Hz to 20 Hz. The moment of inertia of flywheel about its axis of rotation is ($\pi^2 = 10$)

- Ans
- 1. 1 kgm^2
 - 2. 2 kgm^2
 - 3. 1.688 kgm^2
 - 4. 1.5 kgm^2

Question Type : MCQ

Question ID : 588552779

Option 1 ID : 5885523115

Option 2 ID : 5885523114

Option 3 ID : 5885523113

Option 4 ID : 5885523116

Status : Answered

Chosen Option : 2

Q.4 A rigid body is rotating with angular velocity ' ω ' about an axis of rotation. Let ' v ' be the linear
1 velocity of particle which is at perpendicular distance ' r ' from the axis of rotation. Then the
relation ' $v = r\omega$ ' implies that

- Ans
- 1. ω does not depend on r
 - 2. $\omega \propto \frac{1}{r}$
 - 3. $\omega \propto r$
 - 4. $\omega = 0$

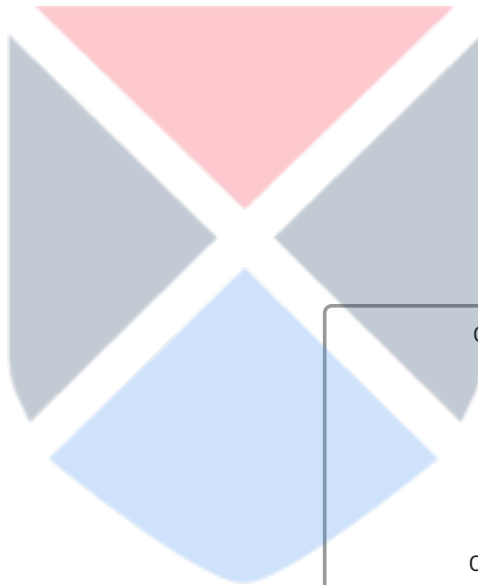

Question Type : MCQ

Question ID : 588552754

Option 1 ID : 5885523013

Option 2 ID : 5885523015

Option 3 ID : 5885523014

Option 4 ID : 5885523016

Status : Answered

Chosen Option : 1

Q.4 In the given electrical circuit, which one of the following equations is a correct equation ?
2

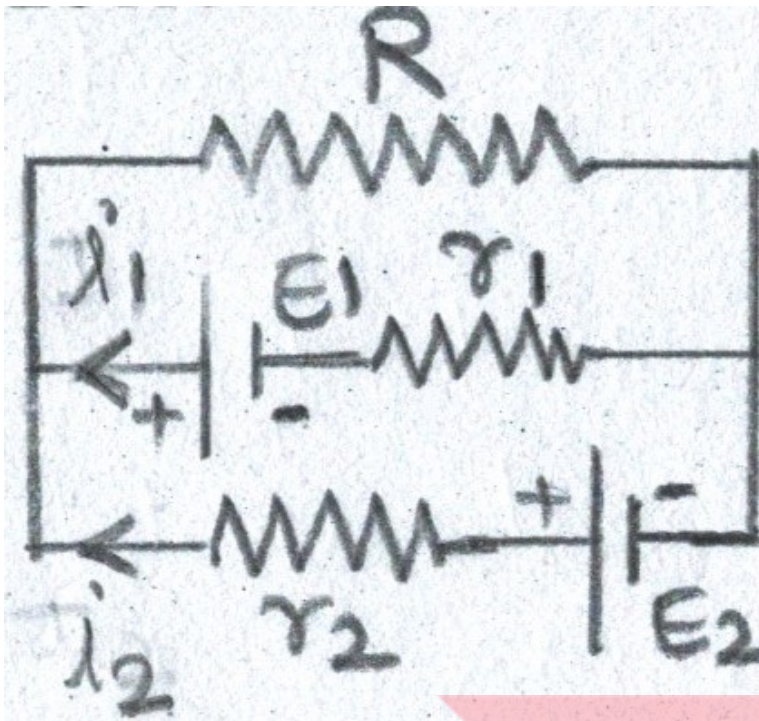

Ans

1. $E_2 - i_2 r_2 - E_1 - i_1 r_1 = 0$

2. $E_1 - (i_1 + i_2)R + i_1 r_1 = 0$

3. $E_1 - (i_1 + i_2)R - i_1 r_1 = 0$

4. $-E_2 - (i_1 + i_2)R + i_2 r_2 = 0$

Question Type : MCQ

Question ID : 588552775

Option 1 ID : 5885523099

Option 2 ID : 5885523097

Option 3 ID : 5885523100

Option 4 ID : 5885523098

Status : Answered

Chosen Option : 3

Q.4 The maximum wavelength of radiation emitted by a star is 289.8 nm. Then intensity of radiation for the star is (Given : Stefan's constant = $5.67 \times 10^{-8} \text{ Wm}^{-2}\text{K}^{-4}$, Wien's constant, $b = 2898 \mu\text{mK}$)

Ans 1. $5.67 \times 10^{-12} \text{ Wm}^{-2}$

2. $10.67 \times 10^{14} \text{ Wm}^{-2}$

3. $5.67 \times 10^8 \text{ Wm}^{-2}$

4. $10.67 \times 10^7 \text{ Wm}^{-2}$

Question Type : MCQ

Question ID : 588552772

Option 1 ID : 5885523085
Option 2 ID : 5885523088
Option 3 ID : 5885523087
Option 4 ID : 5885523086
Status : Answered
Chosen Option : 3

Q.4 A lift is tied with thick iron ropes having mass 'M'. The maximum acceleration of the lift is 'a'
4 m/s^2 and maximum safe stress is 'S' N/m^2 . The minimum diameter of the rope is

Ans

1. $[6 M(g + a)/\pi S]^{1/2}$

2. $[4 M(g + a)/\pi S]^{1/2}$

3. $[M(g + a)/\pi S]^{1/2}$

4. $[M(g - a)/\pi S]^{1/2}$

Question Type : MCQ

Question ID : 588552794

Option 1 ID : 5885523176

Option 2 ID : 5885523175

Option 3 ID : 5885523174

Option 4 ID : 5885523173

Status : Answered

Chosen Option : 2

Q.4 In Balmer series, wavelength of first line is ' λ_1 ' and in Brackett series wavelength of
5 first line is ' λ_2 ' then λ_1/λ_2 is

Ans 1. 0.162

2. 0.124

3. 0.138

4. 0.188

Question Type : MCQ

Question ID : 588552771

Option 1 ID : 5885523083

Option 2 ID : 5885523081

Option 3 ID : 5885523082

Option 4 ID : 5885523084

Status : Answered

Chosen Option : 1

Q.4 An alternating voltage is given by $E = 100 \sin(\omega t + \pi/6)$ V. The voltage will be maximum for the first
6 time when $t =$ [T = periodic time]

Ans

1. $\frac{T}{12}$

2. $\frac{T}{2}$

3. $\frac{T}{6}$

4. $\frac{T}{3}$

Question Type : MCQ

Question ID : 588552763

Option 1 ID : 5885523052

Option 2 ID : 5885523050

Option 3 ID : 5885523051

Option 4 ID : 5885523049

Status : Answered

Chosen Option : 3

Q.4 In frequency modulated wave

7

Ans 1. frequency varies with time.

2. both frequency and amplitude vary with time.

3. amplitude varies with time.

4. both frequency and amplitude are constant.

Question Type : MCQ

Question ID : 588552753

Option 1 ID : 5885523010

Option 2 ID : 5885523012

Option 3 ID : 5885523009

Option 4 ID : 5885523011

Status : Marked For Review

Chosen Option : 1

Q.4 With a resistance of 'X' in the left gap and a resistance of 9 Ω in the right gap of a meter
8 bridge, the balance point is obtained at 40 cm from the left end. In what way and to which
resistance 3 Ω resistance be connected to obtain the balance at 50 cm from the left end ?

Ans 1. in series with 9 Ω

2. parallel to X Ω

3. in series with X Ω

4. parallel to 9 Ω

Question Type : MCQ

Question ID : 588552798

Option 1 ID : 5885523192

Option 2 ID : 5885523189

Option 3 ID : 5885523191

Option 4 ID : 5885523190

Q.4 The excess of pressure, due to surface tension, on a spherical liquid drop of radius 'R' is proportional to

Ans

✓ 1. R^{-1}

✗ 2. R

✗ 3. R^{-2}

✗ 4. R^2

Question Type : MCQ

Question ID : 588552761

Option 1 ID : 5885523044

Option 2 ID : 5885523041

Option 3 ID : 5885523043

Option 4 ID : 5885523042

Status : Answered

Chosen Option : 1

Q.5 \vec{P} and \vec{Q} are two non-zero vectors inclined to each other at an angle ' θ '. ' \hat{P} ' and ' \hat{q} ' are unit vectors along \vec{P} and \vec{Q} respectively. The component of \vec{Q} in the direction of \vec{P} will be

Ans

✓ 1. $\hat{P} \cdot \vec{Q}$

✗ 2. $\frac{\vec{P} \times \vec{Q}}{P}$

✗ 3. $\frac{\vec{P} \cdot \vec{Q}}{Q}$

✗ 4. $\vec{P} \cdot \hat{q}$

Question Type : MCQ

Question ID : 588552787

Option 1 ID : 5885523147

Option 2 ID : 5885523146

Option 3 ID : 5885523145

Option 4 ID : 5885523148

Status : Answered

Chosen Option : 1

Q.1 The number of σ and π bonds in 2-formylbenzoic acid are respectively

- Ans
- 1. 10,3
 - 2. 14,3
 - 3. 12,5
 - 4. 17,5

Question Type : MCQ
Question ID : 588552804
Option 1 ID : 5885523216
Option 2 ID : 5885523214
Option 3 ID : 5885523215
Option 4 ID : 5885523213
Status : Answered
Chosen Option : 4

Q.2 The volume of 1 mole of any pure gas at standard temperature and pressure is always equal to

- Ans
- 1. 0.022414 m³
 - 2. 22.414 m³
 - 3. 2.2414 m³
 - 4. 0.22414 m³

Question Type : MCQ
Question ID : 588552831
Option 1 ID : 5885523323
Option 2 ID : 5885523324
Option 3 ID : 5885523322
Option 4 ID : 5885523321
Status : Answered
Chosen Option : 1

Q.3 Veronal is used as a/an

- Ans
- 1. analgesic
 - 2. antihistamine
 - 3. antibiotic
 - 4. tranquilizer

Question Type : MCQ
Question ID : 588552839
Option 1 ID : 5885523353
Option 2 ID : 5885523356
Option 3 ID : 5885523354
Option 4 ID : 5885523355
Status : Answered
Chosen Option : 4

Q.4 Which of the following is also called as nitrogen sesquioxide ?

- Ans
- 1. NO₂
 - 2. N₂O₃
 - 3. N₂O₄

4. N_2O_5

Question Type : MCQ

Question ID : 588552818

Option 1 ID : 5885523270

Option 2 ID : 5885523269

Option 3 ID : 5885523271

Option 4 ID : 5885523272

Status : Marked For Review

Chosen Option : 2

Q.5 The oxidation number of sulphur in S_8 molecule is

Ans 1. 6

2. 0

3. 2

4. 3

Question Type : MCQ

Question ID : 588552827

Option 1 ID : 5885523308

Option 2 ID : 5885523305

Option 3 ID : 5885523306

Option 4 ID : 5885523307

Status : Answered

Chosen Option : 2

Q.6 Which among the following is a set of nucleophiles ?

Ans 1. H^+ , NH_3 , Cl^-

2. BF_3 , H_2O , NH_3

3. AlCl_3 , BF_3 , NH_3

4. CN^- , H_2O , R-OH

Question Type : MCQ

Question ID : 588552833

Option 1 ID : 5885523332

Option 2 ID : 5885523329

Option 3 ID : 5885523330

Option 4 ID : 5885523331

Status : Answered

Chosen Option : 4

Q.7 Which of the following acts as oxidising agent in hydrogen - oxygen fuel cell ?

Ans 1. H_2

2. O_2

3. KOH

4. C

Question Type : MCQ

Question ID : 588552810

Option 1 ID : 5885523238

Option 2 ID : 5885523237

Option 3 ID : 5885523240

Option 4 ID : 5885523239
Status : Answered
Chosen Option : 2

Q.8 In ozone molecule , the formal charge on the central oxygen atom is

- Ans
- 1. -1
 - 2. +2
 - 3. 0
 - 4. +1

Question Type : MCQ
Question ID : 588552837
Option 1 ID : 5885523345
Option 2 ID : 5885523348
Option 3 ID : 5885523346
Option 4 ID : 5885523347
Status : Answered
Chosen Option : 4

Q.9 According to Werners theory , the geometry of the complex is determined by

- Ans
- 1. only from the primary valence in space
 - 2. number and position of the primary valences in space
 - 3. number and position of the secondary valences in space
 - 4. only from the position of secondary valence in space

Question Type : MCQ
Question ID : 588552815
Option 1 ID : 5885523259
Option 2 ID : 5885523258
Option 3 ID : 5885523257
Option 4 ID : 5885523260
Status : Answered
Chosen Option : 3

Q.1 How many total constituent particles are present in simple cubic unit cell ?

- 0
- Ans
- 1. 1
 - 2. 3
 - 3. 4
 - 4. 2

Question Type : MCQ
Question ID : 588552847
Option 1 ID : 5885523385
Option 2 ID : 5885523387
Option 3 ID : 5885523388
Option 4 ID : 5885523386
Status : Answered
Chosen Option : 1

Q.1 The correct representation of Nernst's equation for half-cell reaction $\text{Cu}^{2+}_{(\text{aq})} + \text{e}^- \rightarrow \text{Cu}_{(\text{aq})}$ is

1
Ans

$$1. E^0_{\text{Cu}^+, \text{Cu}^{2+}} = E_{\text{Cu}^+, \text{Cu}^{2+}} - \frac{0.0592}{2} \text{Log} \frac{[\text{Cu}^+]}{[\text{Cu}^{2+}]}$$

$$2. E_{\text{Cu}^+, \text{Cu}^{2+}} = E^0_{\text{Cu}^+, \text{Cu}^{2+}} - \frac{0.0592}{1} \text{Log} \frac{[\text{Cu}^+]}{[\text{Cu}^{2+}]}$$

$$3. E^0_{\text{Cu}^+, \text{Cu}^{2+}} = E_{\text{Cu}^+, \text{Cu}^{2+}} + \frac{0.0592}{2} \text{Log} \frac{[\text{Cu}^+]}{[\text{Cu}^{2+}]}$$

$$4. E_{\text{Cu}^+, \text{Cu}^{2+}} = E^0_{\text{Cu}^+, \text{Cu}^{2+}} - \frac{0.0592}{1} \text{Log} \frac{[\text{Cu}^+]}{[\text{Cu}^{2+}]}$$

Note: For this question, discrepancy is found in question/answer. Full Marks is being awarded to all candidates.

Question Type : MCQ

Question ID : 588552807

Option 1 ID : 5885523225

Option 2 ID : 5885523228

Option 3 ID : 5885523226

Option 4 ID : 5885523227

Status : Answered

Chosen Option : 4

Q.1 Which among the following is a neutral complex ?

2

Ans 1. $[\text{Fe}(\text{H}_2\text{O})_6]\text{Cl}_3$

2. $[\text{Ni}(\text{NH}_3)_6]\text{Cl}_2$

3. $[\text{Pt}(\text{NH}_3)_2\text{Cl}_2]$

4. $\text{K}[\text{Ag}(\text{CN})_2]$

Question Type : MCQ

Question ID : 588552823

Option 1 ID : 5885523292

Option 2 ID : 5885523291

Option 3 ID : 5885523289

Option 4 ID : 5885523290

Status : Answered

Chosen Option : 3

Q.1 Identify the equation in which change in enthalpy is equal to change in internal energy

3

Ans 1. $2\text{H}_2\text{O}_2(\text{l}) \rightarrow 2\text{H}_2\text{O}(\text{l}) + \text{O}_2(\text{g})$

2. $\text{C}(\text{s}) + \text{O}_2(\text{g}) \rightarrow \text{CO}_2(\text{g})$

3. $\text{PCl}_5(\text{g}) \rightarrow \text{PCl}_3(\text{g}) + \text{Cl}_2(\text{g})$

4. $\text{N}_2(\text{g}) + 3\text{H}_2(\text{g}) \rightarrow 2\text{NH}_3(\text{g})$

Question Type : MCQ

Question ID : 588552836

Option 1 ID : 5885523342

Option 2 ID : 5885523341

Option 3 ID : 5885523343

Option 4 ID : 5885523344

Status : Answered

Chosen Option : 2

Q.1 Limestone is used as a flux in the extraction of

4

Ans 1. iron

2. aluminium

3. zinc

4. copper

Question Type : MCQ

Question ID : 588552816

Option 1 ID : 5885523263

Option 2 ID : 5885523262

Option 3 ID : 5885523264

Option 4 ID : 5885523261

Status : Marked For Review

Chosen Option : 1

Q.1 Which among the following does not form polyhalide ion ?

5

Ans 1. Chlorine

2. Bromine

3. Iodine

4. Fluorine

Question Type : MCQ

Question ID : 588552811

Option 1 ID : 5885523241

Option 2 ID : 5885523243

Option 3 ID : 5885523244

Option 4 ID : 5885523242

Status : Answered

Chosen Option : 4

Q.1 How many isomers are possible for an alkane having molecular formula C_5H_{12} ?

6

Ans 1. 5

2. 3

3. 4

4. 2

Question Type : MCQ

Question ID : 588552801

Option 1 ID : 5885523204

Option 2 ID : 5885523202

Option 3 ID : 5885523203

Option 4 ID : 5885523201
Status : Marked For Review
Chosen Option : 2

Q.1 Which of following elements does not form amide when reacted with ammonia ?

7

- Ans
- 1. Li
 - 2. Na
 - 3. K
 - 4. Rb

Question Type : MCQ
Question ID : 588552845
Option 1 ID : 5885523380
Option 2 ID : 5885523379
Option 3 ID : 5885523378
Option 4 ID : 5885523377
Status : Marked For Review
Chosen Option : 1

Q.1 Two moles of an ideal gas is expanded isothermally and reversibly at 300 K from 1L to 10 L .

8 The enthalpy change in kJ is

- Ans
- 1. 11.4 kJ
 - 2. 4.8 kJ
 - 3. -11.4 kJ
 - 4. Zero kJ

Question Type : MCQ
Question ID : 588552832
Option 1 ID : 5885523327
Option 2 ID : 5885523326
Option 3 ID : 5885523328
Option 4 ID : 5885523325
Status : Answered
Chosen Option : 4

Q.1 α -Chlorosodium acetate on boiling with aqueous sodium nitrite gives

9

- Ans
- 1. nitromethane
 - 2. α -chloronitromethane
 - 3. nitroethane
 - 4. acetyl chloride

Question Type : MCQ
Question ID : 588552829
Option 1 ID : 5885523313
Option 2 ID : 5885523316
Option 3 ID : 5885523314
Option 4 ID : 5885523315
Status : Answered
Chosen Option : 1

Q.2 The bond angle H-O-O in H_2O_2 in gaseous phase is

0

- Ans 1. 90.2^0
 2. 111.5^0
 3. 101.9^0
 4. 94.8^0

Question Type : MCQ
Question ID : 588552834
Option 1 ID : 5885523335
Option 2 ID : 5885523334
Option 3 ID : 5885523333
Option 4 ID : 5885523336
Status : Answered
Chosen Option : 3

Q.2 How many metameric ethers are represented by the molecular formula $C_4H_{10}O$?

1

- Ans 1. 4
 2. 3
 3. 2
 4. 5

Question Type : MCQ
Question ID : 588552814
Option 1 ID : 5885523255
Option 2 ID : 5885523254
Option 3 ID : 5885523253
Option 4 ID : 5885523256
Status : Answered
Chosen Option : 2

Q.2 The activation energy of a reaction is zero. Its rate constant at 280 K is $1.6 \times 10^{-6} S^{-1}$, the rate constant at 300 K is

2

- Ans 1. $3.2 \times 10^{-6} S^{-1}$
 2. Zero
 3. $1.6 \times 10^{-6} S^{-1}$
 4. $1.6 \times 10^{-5} S^{-1}$

Question Type : MCQ
Question ID : 588552802
Option 1 ID : 5885523208
Option 2 ID : 5885523205
Option 3 ID : 5885523206
Option 4 ID : 5885523207
Status : Answered
Chosen Option : 3

Q.2 Which of following metals occurs in native state ?

3

- Ans 1. Magnesium
 2. Platinum
 3. Potassium

4. Sodium

Question Type : MCQ

Question ID : 588552819

Option 1 ID : 5885523276

Option 2 ID : 5885523275

Option 3 ID : 5885523274

Option 4 ID : 5885523273

Status : Answered

Chosen Option : 2

Q.2 Which of the following is NOT a broadspectrum antibiotics ?

4

Ans 1. Penicillin

2. Amoxicillin

3. Chloramphenicol

4. Ampicillin

Question Type : MCQ

Question ID : 588552838

Option 1 ID : 5885523350

Option 2 ID : 5885523349

Option 3 ID : 5885523351

Option 4 ID : 5885523352

Status : Answered

Chosen Option : 1

Q.2 The oxidation state of sulphur in $H_2S_2O_7$ is

5

Ans 1. +4

2. +6

3. +5

4. +7

Question Type : MCQ

Question ID : 588552826

Option 1 ID : 5885523301

Option 2 ID : 5885523303

Option 3 ID : 5885523302

Option 4 ID : 5885523304

Status : Answered

Chosen Option : 2

Q.2 The reaction in which 2 molecules of chlorobenzene reacts with metallic sodium in presence

6 of dry ether forming diphenyl is an example of,

Ans 1. Wurtz-Fittig reaction

2. Wurtz reaction

3. Rosenmund reaction

4. Balz-Schiemann reaction

Question Type : MCQ

Question ID : 588552821

Option 1 ID : 5885523284

Option 2 ID : 5885523283
Option 3 ID : 5885523282
Option 4 ID : 5885523281
Status : Answered
Chosen Option : 1

Q.2 The percentage of unoccupied volume in simple cubic cell is

7

- Ans
- 1. 52.40 %
 - 2. 32.00 %
 - 3. 47.60 %
 - 4. 68.04 %

Question Type : MCQ
Question ID : 588552843
Option 1 ID : 5885523369
Option 2 ID : 5885523372
Option 3 ID : 5885523370
Option 4 ID : 5885523371
Status : Answered
Chosen Option : 3

Q.2 Isobutylene on hydroboration followed by oxidation with hydrogen peroxide in presence of base yields

8

- Ans
- 1. n-butyl alcohol
 - 2. sec-butyl alcohol
 - 3. tert-butyl alcohol
 - 4. isobutyl alcohol

Question Type : MCQ
Question ID : 588552817
Option 1 ID : 5885523265
Option 2 ID : 5885523267
Option 3 ID : 5885523268
Option 4 ID : 5885523266
Status : Answered
Chosen Option : 4

Q.2 What is the density of water vapour at boiling point of water ?

9

- Ans
- 1. $1 \times 10^{-4} \text{ g cm}^{-3}$
 - 2. 1 g cm^{-3}
 - 3. $6 \times 10^{-4} \text{ g cm}^{-3}$
 - 4. $4 \times 10^{-4} \text{ g cm}^{-3}$

Question Type : MCQ
Question ID : 588552835
Option 1 ID : 5885523338
Option 2 ID : 5885523337
Option 3 ID : 5885523339
Option 4 ID : 5885523340
Status : Answered
Chosen Option : 3

Q.3 Which of the following molecules form a zwitter ion ?

0

- Ans
- 1. $\text{CH}_3\text{COOCH}_3$
 - 2. $\text{H}_2\text{NCH}_2\text{COOH}$
 - 3. $\text{CH}_3\text{COC}_2\text{H}_5$
 - 4. $\text{CH}_3\text{CH}_2\text{COOH}$

Question Type : MCQ

Question ID : 588552842

Option 1 ID : 5885523365

Option 2 ID : 5885523367

Option 3 ID : 5885523366

Option 4 ID : 5885523368

Status : Answered

Chosen Option : 2

Q.3 Which reaction is useful in exchange of halogen in alkyl chloride by iodide ?

1

- Ans
- 1. Wurtz reaction
 - 2. Finkelstein reaction
 - 3. Reimer-Tiemann reaction
 - 4. Williamson synthesis

Question Type : MCQ

Question ID : 588552812

Option 1 ID : 5885523245

Option 2 ID : 5885523248

Option 3 ID : 5885523246

Option 4 ID : 5885523247

Status : Answered

Chosen Option : 2

Q.3 Propene when treated with cold conc. H_2SO_4 forms a compound which on heating with water

2 gives

- Ans
- 1. propan-2-ol
 - 2. butan-1-ol
 - 3. ethanol
 - 4. propan-1-ol

Question Type : MCQ

Question ID : 588552813

Option 1 ID : 5885523251

Option 2 ID : 5885523252

Option 3 ID : 5885523249

Option 4 ID : 5885523250

Status : Answered

Chosen Option : 1

Q.3 Identify the amine formed when ethyltrimethyl ammonium iodide is treated with silver hydroxide and further heated strongly

3

- Ans
- 1. $\text{C}_2\text{H}_5\text{N}(\text{CH}_3)_2$
 - 2. $\text{C}_2\text{H}_5\text{NH}_2$

3. $(\text{CH}_3)_3\text{N}$

4. CH_3NH_2

Question Type : MCQ

Question ID : 588552803

Option 1 ID : 5885523211

Option 2 ID : 5885523209

Option 3 ID : 5885523212

Option 4 ID : 5885523210

Status : Answered

Chosen Option : 3

Q.3 For a chemical reaction rate law is, $\text{rate} = k [\text{A}]^2 [\text{B}]$. If [A] is doubled at constant [B], the rate of reaction

Ans 1. increases by a factor of 8

2. increases by a factor of 4

3. increases by a factor of 3

4. increases by a factor of 2

Question Type : MCQ

Question ID : 588552809

Option 1 ID : 5885523236

Option 2 ID : 5885523235

Option 3 ID : 5885523234

Option 4 ID : 5885523233

Status : Answered

Chosen Option : 2

Q.3 Which of the following is a natural polymer ?

5

Ans 1. Nylon

2. Teflon

3. Linen

4. Orlon

Question Type : MCQ

Question ID : 588552849

Option 1 ID : 5885523393

Option 2 ID : 5885523395

Option 3 ID : 5885523396

Option 4 ID : 5885523394

Status : Answered

Chosen Option : 3

Q.3 The monomers used in the preparation of dextran are

6

Ans 1. glycine and ω - amino caproic acid

2. 3- Hydroxybutanoic acid and 3-hydroxy pentanoic acid

3. glycine and lactic acid

4. lactic acid and glycollic acid

Question Type : MCQ

Question ID : 588552848

Option 1 ID : 5885523392
Option 2 ID : 5885523389
Option 3 ID : 5885523390
Option 4 ID : 5885523391
Status : Answered
Chosen Option : 4

Q.3 When a mixture of manganese dioxide, potassium hydroxide and potassium chlorate is fused ,
7 the product obtained is

- Ans
- 1. K_2SO_4
 - 2. K_2MnO_3
 - 3. K_2MnO_4
 - 4. $KMnO_4$

Question Type : MCQ
Question ID : 588552822
Option 1 ID : 5885523285
Option 2 ID : 5885523286
Option 3 ID : 5885523287
Option 4 ID : 5885523288
Status : Answered
Chosen Option : 3

Q.3 In which oxidation state, group 15 elements act as Lewis base ?
8

- Ans
- 1. +5
 - 2. +4
 - 3. -3
 - 4. +3

Question Type : MCQ
Question ID : 588552805
Option 1 ID : 5885523220
Option 2 ID : 5885523219
Option 3 ID : 5885523218
Option 4 ID : 5885523217
Status : Answered
Chosen Option : 3

Q.3 Relationship between vant Hoff factor (i) and degree of dissociation (α) is
9

- Ans
- 1. $i = \frac{\alpha - 1}{n' - 1}$
 - 2. $i = \frac{\alpha - 1}{1 - n'}$
 - 3. $\alpha = \frac{1 - i}{n' - 1}$

✓ 4. $\alpha = \frac{i - 1}{n' - 1}$

Question Type : MCQ

Question ID : 588552841

Option 1 ID : 5885523363

Option 2 ID : 5885523361

Option 3 ID : 5885523362

Option 4 ID : 5885523364

Status : Answered

Chosen Option : 4

Q.4 Which of following elements does NOT react with hot concentrated sulphuric acid ?

0

Ans ✗ 1. Sb

✓ 2. N

✗ 3. P

✗ 4. As

Question Type : MCQ

Question ID : 588552825

Option 1 ID : 5885523299

Option 2 ID : 5885523300

Option 3 ID : 5885523297

Option 4 ID : 5885523298

Status : Answered

Chosen Option : 1

Q.4

1

In the reaction, $\text{H}_2\text{O}_{2(aq)} \xrightarrow{\text{I}^-_{(aq)}} \text{H}_2\text{O}_{(l)} + \frac{1}{2} \text{O}_{2(g)}$ iodide ion acts as

Ans ✓ 1. homogenous catalyst

✗ 2. acid catalyst

✗ 3. Heterogenous catalyst

✗ 4. enzyme catalyst

Question Type : MCQ

Question ID : 588552830

Option 1 ID : 5885523318

Option 2 ID : 5885523320

Option 3 ID : 5885523317

Option 4 ID : 5885523319

Status : Answered

Chosen Option : 3

Q.4 The ionic charges of manganate and permanganate ion are respectively

2

- Ans 1. -2,-2
 2. -1,-2
 3. -2,-1
 4. -1,-1

Question Type : MCQ
Question ID : 588552850
Option 1 ID : 5885523397
Option 2 ID : 5885523398
Option 3 ID : 5885523399
Option 4 ID : 5885523400
Status : Answered
Chosen Option : 3

Q.4 How many gram of sodium (atomic mass 23 u) is required to prepare one mole of ethane from 3 methyl chloride by wurtz reaction ?

- Ans 1. 2
 2. 23
 3. 11.5
 4. 46

Question Type : MCQ
Question ID : 588552828
Option 1 ID : 5885523312
Option 2 ID : 5885523309
Option 3 ID : 5885523310
Option 4 ID : 5885523311
Status : Answered
Chosen Option : 4

Q.4 The enzyme which converts maltose to glucose is

- 4
Ans 1. maltase
 2. insulin
 3. lysine
 4. zymase

Question Type : MCQ
Question ID : 588552844
Option 1 ID : 5885523373
Option 2 ID : 5885523374
Option 3 ID : 5885523376
Option 4 ID : 5885523375
Status : Answered
Chosen Option : 1

Q.4
5 If $C_{(s)} + O_{2(g)} \rightarrow CO_{2(g)} \Delta H = -X$, $CO_{(g)} + \frac{1}{2} O_{2(g)} \rightarrow CO_{2(g)} \Delta H = -Y$, Calculate $\Delta_f H$ for $CO_{(g)}$ formation

- Ans 1. -Y-X
 2. Y-X

3. X+Y

4. X-Y

Question Type : MCQ

Question ID : 588552820

Option 1 ID : 5885523280

Option 2 ID : 5885523278

Option 3 ID : 5885523279

Option 4 ID : 5885523277

Status : Answered

Chosen Option : 2

Q.4 What is the atomicity of aluminium phosphate ?

6

Ans 1. 8

2. 6

3. 5

4. 13

Question Type : MCQ

Question ID : 588552824

Option 1 ID : 5885523293

Option 2 ID : 5885523295

Option 3 ID : 5885523294

Option 4 ID : 5885523296

Status : Answered

Chosen Option : 2

Q.4 Which among the following compounds is obtained when ethanenitrile is acid hydrolysed?

7

Ans 1. Formic acid

2. Acetamide

3. Formamide

4. Acetic acid

Question Type : MCQ

Question ID : 588552806

Option 1 ID : 5885523221

Option 2 ID : 5885523224

Option 3 ID : 5885523222

Option 4 ID : 5885523223

Status : Answered

Chosen Option : 4

Q.4 Standard Hydrogen electrode (SHE) is a

8

Ans 1. Primary reference electrode

2. Secondary reference electrode

3. Metal - Sparingly soluble salt electrode

4. Metal - Metal ion electrode

Question Type : MCQ

Question ID : 588552808

Option 1 ID : 5885523230
Option 2 ID : 5885523229
Option 3 ID : 5885523231
Option 4 ID : 5885523232
Status : Answered
Chosen Option : 1

Q.4 9 gram anhydrous oxalic acid (Mol. Wt = 90) was dissolved in 9.9 moles of water. If vapour pressure of pure water is P_1^0 , the vapour pressure of solution is

- Ans 1. $0.99 P_1^0$
 2. $0.1 P_1^0$
 3. $0.90 P_1^0$
 4. $1.1 P_1^0$

Question Type : MCQ
Question ID : 588552840
Option 1 ID : 5885523357
Option 2 ID : 5885523359
Option 3 ID : 5885523358
Option 4 ID : 5885523360
Status : Answered
Chosen Option : 1

Q.5 Which of the following sets of solutions of urea (mol. mass. 60 g mol^{-1}) and sucrose (mol. mass. 342 g mol^{-1}) is isotonic ?

- Ans 1. 9.1 gL^{-1} urea and 6.0 gL^{-1} sucrose
 2. 3.0 gL^{-1} urea and 3.0 gL^{-1} sucrose
 3. 6.0 gL^{-1} urea and 9.0 gL^{-1} sucrose
 4. 3.0 gL^{-1} urea and 17.1 gL^{-1} sucrose

Question Type : MCQ
Question ID : 588552846
Option 1 ID : 5885523384
Option 2 ID : 5885523381
Option 3 ID : 5885523382
Option 4 ID : 5885523383
Status : Answered
Chosen Option : 4

Section : Mathematics

Q.1 In a binomial distribution, mean is 18 and variance is 12 then $p = \dots\dots$

Ans

1. $\frac{2}{3}$

✓ 2. $\frac{1}{3}$

✗ 3. $\frac{3}{4}$

✗ 4. $\frac{1}{2}$

Question Type : MCQ

Question ID : 588552864

Option 1 ID : 5885523454

Option 2 ID : 5885523453

Option 3 ID : 5885523456

Option 4 ID : 5885523455

Status : Answered

Chosen Option : 2

Q.2 If lines $\frac{x-1}{2} = \frac{y+1}{3} = \frac{z-1}{4}$ and $\frac{x-3}{1} = \frac{y-\lambda}{2} = \frac{z}{1}$ intersect each other, then $\lambda = \dots$

Ans

✗ 1. $\frac{7}{2}$

✗ 2. $\frac{3}{2}$

✓ 3. $\frac{9}{2}$

✗ 4. $\frac{5}{2}$

Question Type : MCQ
Question ID : 588552882
Option 1 ID : 5885523528
Option 2 ID : 5885523526
Option 3 ID : 5885523527
Option 4 ID : 5885523525
Status : Answered
Chosen Option : 3

Q.3 The particular solution of the differential equation $\log\left(\frac{dy}{dx}\right) = x$, when $x = 0, y = 1$ is

Ans

✗ 1. $y = e^x + 2$

✗ 2. $y = -e^x$

✗ 3. $y = -e^x + 2$

✓ 4. $y = e^x$

Question Type : MCQ
Question ID : 588552865
Option 1 ID : 5885523458
Option 2 ID : 5885523457
Option 3 ID : 5885523459
Option 4 ID : 5885523460
Status : Answered
Chosen Option : 4

Q.4 The p.d.f of a random variable x is given by $f(x) = \frac{1}{4a}$, $0 < x < 4a$, ($a > 0$)
 $= 0$, otherwise.

and $P\left(x < \frac{3a}{2}\right) = kP\left(x > \frac{5a}{2}\right)$ then $k = \dots\dots\dots$

Ans ✓ 1.1

✗ 2. $\frac{1}{4}$

3. $\frac{1}{8}$

4. $\frac{1}{2}$

Question Type : MCQ

Question ID : 588552877

Option 1 ID : 5885523505

Option 2 ID : 5885523507

Option 3 ID : 5885523508

Option 4 ID : 5885523506

Status : Answered

Chosen Option : 1

Q.5

If the function $f(x) = \frac{(e^{kx}-1)\tan kx}{4x^2}$, $x \neq 0$
 $= 16$, $x = 0$

Is continuous at $x = 0$, then $k = \dots\dots$

Ans

1. $\pm \frac{1}{8}$

2. ± 4

3. ± 2

4. ± 8

Question Type : MCQ

Question ID : 588552893

Option 1 ID : 5885523572

Option 2 ID : 5885523569

Option 3 ID : 5885523570

Option 4 ID : 5885523571

Status : Answered

Q.6 The solution of the differential equation $ydx - xdy = xydx$ is

Ans

✗ 1. $x^2 = e^x y^2$

✓ 2. $x = ye^x$

✗ 3. $xy = e^x$

✗ 4. $x^2 y^2 = \log x$

Question Type : MCQ

Question ID : 588552890

Option 1 ID : 5885523559

Option 2 ID : 5885523560

Option 3 ID : 5885523557

Option 4 ID : 5885523558

Status : Answered

Chosen Option : 2

Q.7 The maximum value of $z = 6x + 8y$ subject to $x - y \geq 0$, $x + 3y \leq 12$, $x \geq 0$, $y \geq 0$ is

Ans ✓ 1. 72

✗ 2. 42

✗ 3. 96

✗ 4. 24

Question Type : MCQ

Question ID : 588552881

Option 1 ID : 5885523524

Option 2 ID : 5885523523

Option 3 ID : 5885523522

Option 4 ID : 5885523521

Status : Answered

Chosen Option : 1

Q.8

If $\sum_{r=1}^n (2r + 1) = 440$, then $n = \dots\dots\dots$

Ans ✓ 1. 20

✗ 2. 22

✗ 3. 21

✗ 4. 19

Question Type : MCQ

Question ID : 588552899

Option 1 ID : 5885523593

Option 2 ID : 5885523594

Option 3 ID : 5885523596

Option 4 ID : 5885523595

Status : Answered

Chosen Option : 1

Q.9 If p and q are true and r and s are false statements, then which of the following is true?

Ans

1. $(q \wedge r) \vee (\sim p \wedge s)$

2. $(\sim p \rightarrow q) \leftrightarrow (r \wedge s)$

3. $(p \rightarrow q) \vee (r \leftrightarrow s)$

4. $(p \wedge \sim r) \wedge (\sim q \vee s)$

Question Type : MCQ

Question ID : 588552873

Option 1 ID : 5885523492

Option 2 ID : 5885523490

Option 3 ID : 5885523491

Option 4 ID : 5885523489

Status : Answered

Chosen Option : 3

Q.10 If the standard deviation of the random variable X is $\sqrt{3pq}$ and mean is $3p$ then $E(X^2) = \dots\dots$

1. $3pq + 3q^2$

2. $3p(1 + 2p)$

3. $3pq + 3p^2$

4. $3q(1 + 2q)$

Question Type : MCQ

Question ID : 588552852

Option 1 ID : 5885523407

Option 2 ID : 5885523405

Option 3 ID : 5885523406

Option 4 ID : 5885523408

Status : Marked For Review

Chosen Option : 3

1 If $f(x) = [x]$, where $[x]$ is the greatest integer not greater than x , then $f'(1^+) = \dots$

- Ans
- 1. 1
 - 2. 2
 - 3. 0
 - 4. -1

Question Type : MCQ

Question ID : 588552867

Option 1 ID : 5885523465

Option 2 ID : 5885523468

Option 3 ID : 5885523466

Option 4 ID : 5885523467

Status : Answered

Chosen Option : 3

Q.1
2 If lines represented by $(1 + \sin^2 \theta) x^2 + 2\sin\theta xy + \sin^2 \theta y^2 = 0$, $\theta \in [0, 2\pi]$ are perpendicular to each other then $\theta = \dots$

- Ans
- 1. $\frac{\pi}{2}$
 - 2. π
 - 3. $\frac{3\pi}{2}$
 - 4. $\frac{\pi}{6}$



Question Type : MCQ

Question ID : 588552858

Option 1 ID : 5885523431

Option 2 ID : 5885523429

Option 3 ID : 5885523430

Option 4 ID : 5885523432

Status : Answered

Chosen Option : 3

Q.1
3 If $A = \{x \mid x \in N, x \text{ is a prime number less than } 12\}$ and $B = \{x \mid x \in N, x \text{ is a factor of } 10\}$, then $A \cap B = \dots$

- Ans
- 1. {2}
 - 2. {2,5}
 - 3. {2,5,10}
 - 4. {1,2,5,10}

Question Type : MCQ

Question ID : 588552887

Option 1 ID : 5885523545

Option 2 ID : 5885523546

Option 3 ID : 5885523547

Option 4 ID : 5885523548

Status : Answered

Chosen Option : 2

Q.1
4 If R is the circumradius of ΔABC , then $A(\Delta ABC) = \dots\dots$

Ans

1. $\frac{abc}{R}$

2. $\frac{abc}{4R}$

3. $\frac{abc}{3R}$

4. $\frac{abc}{2R}$



Question Type : MCQ

Question ID : 588552897

Option 1 ID : 5885523585

Option 2 ID : 5885523588

Option 3 ID : 5885523587

Option 4 ID : 5885523586

Status : Answered

Chosen Option : 2

Q.1 If A,B,C and D are (3,7,4),(5,-2,3),(-4,5,6) and (1,2,3) respectively, then the volume of the
5 parallelepiped with AB, AC and AD as the co-terminus edges, is cubic units.

Ans 1. 91

2. 94

3. 92

4. 93

Question Type : MCQ

Question ID : 588552895

Option 1 ID : 5885523579

Option 2 ID : 5885523580

Option 3 ID : 5885523578

Option 4 ID : 5885523577

Status : Answered

Chosen Option : 3

Q.1
6 If $(-\sqrt{2}, \sqrt{2})$ are cartesian co-ordinates of the point, then its polar co-ordinates are

Ans

✗ 1. $(1, \frac{4\pi}{3})$

✓ 2. $(2, \frac{3\pi}{4})$

✗ 3. $(3, \frac{7\pi}{4})$

✗ 4. $(4, \frac{5\pi}{4})$



Question Type : MCQ

Question ID : 588552884

Option 1 ID : 5885523536

Option 2 ID : 5885523535

Option 3 ID : 5885523534

Option 4 ID : 5885523533

Status : Answered

Chosen Option : 2

Q.1
7 If $\int \frac{\cos x - \sin x}{8 - \sin 2x} dx = \frac{1}{p} \log \left[\frac{3 + \sin x + \cos x}{3 - \sin x - \cos x} \right] + c$, then $p = \dots\dots$

Ans

✓ 1. 6

✗ 2. 1

✗ 3. 3

✗ 4. 12

Question Type : MCQ

Question ID : 588552879
Option 1 ID : 5885523513
Option 2 ID : 5885523515
Option 3 ID : 5885523516
Option 4 ID : 5885523514
Status : Answered
Chosen Option : 1

Q.1 If A is non-singular matrix and $(A + I)(A - I) = 0$ then $A + A^{-1} = \dots\dots$
8

- Ans 1. 2A
 2. 0
 3. I
 4. 3I

Question Type : MCQ
Question ID : 588552885
Option 1 ID : 5885523538
Option 2 ID : 5885523540
Option 3 ID : 5885523537
Option 4 ID : 5885523539
Status : Answered
Chosen Option : 1

Q.1 Equations of planes parallel to the plane $x - 2y + 2z + 4 = 0$ which are at a distance
9 of one unit from the point (1,2,3) are

Ans 1.

$$x + 2y + 2z = -6, x + 2y + 2z = 5$$

2.

$$x - 2y - 6 = 0, x - 2y + z = 6$$

3.

$$x + 2y + 2z = 6, x + 2y + 2z = 0$$

4.

$$x - 2y + 2z = 0, x - 2y + 2z - 6 = 0$$

Question Type : MCQ
Question ID : 588552894
Option 1 ID : 5885523575
Option 2 ID : 5885523574
Option 3 ID : 5885523576
Option 4 ID : 5885523573
Status : Answered
Chosen Option : 4

Q.2 The y-intercept of the line passing through A(6,1) and perpendicular to the line $x - 2y = 4$ is
0

Ans

- 1. 5
- 2. 13
- 3. -2
- 4. 26

Question Type : MCQ
 Question ID : 588552875
 Option 1 ID : 5885523499
 Option 2 ID : 5885523497
 Option 3 ID : 5885523500
 Option 4 ID : 5885523498
 Status : Answered
 Chosen Option : 2

Q.2
 1 If function $f(x) = x - \frac{|x|}{x}$, $x < 0$
 $= x + \frac{|x|}{x}$, $x > 0$
 $= 1$, $x = 0$, then

Ans

1. $\lim_{x \rightarrow 0^-} f(x)$ does not exist

2. $\lim_{x \rightarrow 0^+} f(x)$ does not exist

3.

$f(x)$ is continuous at $x = 0$

4. $\lim_{x \rightarrow 0^-} f(x) \neq \lim_{x \rightarrow 0^+} f(x)$

Question Type : MCQ
 Question ID : 588552868
 Option 1 ID : 5885523470
 Option 2 ID : 5885523471
 Option 3 ID : 5885523469
 Option 4 ID : 5885523472
 Status : Answered
 Chosen Option : 4

Q.2
 2 In ΔABC , if $\tan A + \tan B + \tan C = 6$ and $\tan A \cdot \tan B = 2$ then $\tan C = \dots\dots$

- Ans
- 1. 3
 - 2. 4

3.1

4.2

Question Type : MCQ

Question ID : 588552863

Option 1 ID : 5885523451

Option 2 ID : 5885523452

Option 3 ID : 5885523449

Option 4 ID : 5885523450

Status : Answered

Chosen Option : 1

Q.2 If P(6,10,10), Q(1,0,-5) , R(6,-10, λ) are vertices of a triangle right angled at Q, then
3 value of λ is

Ans 1.0

2.1

3.3

4.2

Question Type : MCQ

Question ID : 588552857

Option 1 ID : 5885523425

Option 2 ID : 5885523426

Option 3 ID : 5885523428

Option 4 ID : 5885523427

Status : Answered

Chosen Option : 1

Q.2 For L.P.P, maximize $z = 4x_1 + 2x_2$ subject to $3x_1 + 2x_2 \geq 9$, $x_1 - x_2 \leq 3$,
4 $x_1 \geq 0, x_2 \geq 0$ has

Ans 1. Infinite number of optimal solutions

2. Unbounded solution

3. No solution

4. One optimal solution

Question Type : MCQ

Question ID : 588552856

Option 1 ID : 5885523422

Option 2 ID : 5885523421

Option 3 ID : 5885523423

Option 4 ID : 5885523424

Status : Answered

Chosen Option : 2

Q.2
5 The function $f(x) = x^3 - 3x$ is

Ans 1.

increasing in $(-\infty, -1) \cup (1, \infty)$ and decreasing in $(-1, 1)$

2.

increasing in $(0, \infty)$ and decreasing in $(-\infty, 0)$.

3.

decreasing in $(0, \infty)$ and increasing in $(-\infty, 0)$.

4.

decreasing in $(-\infty, -1) \cup (1, \infty)$ and increasing in $(-1, 1)$

Question Type : MCQ

Question ID : 588552876

Option 1 ID : 5885523501

Option 2 ID : 5885523503

Option 3 ID : 5885523504

Option 4 ID : 5885523502

Status : Answered

Chosen Option : 1

Q.2
6 If $x = \sin\theta$, $y = \sin^3\theta$ then $\frac{d^2y}{dx^2}$ at $\theta = \frac{\pi}{2}$ is

Ans 1. 3

2. 6

3.

$\frac{1}{6}$

4.

$\frac{1}{3}$

Question Type : MCQ

Question ID : 588552880

Option 1 ID : 5885523518

Option 2 ID : 5885523517

Option 3 ID : 5885523519

Option 4 ID : 5885523520

Status : Answered

Chosen Option : 2

Q.2
7 The area of the region enclosed between pair of the lines $xy = 0$ and the lines $xy + 5x - 4y - 20 = 0$, is

Ans 1. 20 square units

2. $\frac{4}{5}$ square units

3. 10 square units

4. 6 square units

Question Type : MCQ

Question ID : 588552896

Option 1 ID : 5885523581

Option 2 ID : 5885523583

Option 3 ID : 5885523582

Option 4 ID : 5885523584

Status : Answered

Chosen Option : 1

Q.2 if three dice are thrown then the probability that the sum of the numbers on their uppermost 8 faces to be at least 5 is

Ans

1. $\frac{1}{53}$

2. $\frac{53}{54}$

3. $\frac{1}{54}$

4. $\frac{52}{53}$



Question Type : MCQ

Question ID : 588552886

Option 1 ID : 5885523544

Option 2 ID : 5885523542

Option 3 ID : 5885523543

Option 4 ID : 5885523541

Status : Answered

Chosen Option : 2

Q.2 If $f(x) = 3x + 6$, $g(x) = 4x + k$ and $f \circ g(x) = g \circ f(x)$ then $k = \dots\dots$

Ans 1. -9

2. 18

3. $\frac{1}{9}$

4. 9

Question Type : MCQ

Question ID : 588552874

Option 1 ID : 5885523493

Option 2 ID : 5885523496

Option 3 ID : 5885523495

Option 4 ID : 5885523494

Status : Answered

Chosen Option : 4

Q.3 If the sum of an infinite G.P be 9 and sum of first two terms be 5 then their common ratio is
0

Ans

1. $\frac{1}{3}$

2. 3

3. $\frac{2}{3}$

4. $\frac{3}{2}$

Question Type : MCQ

Question ID : 588552861

Option 1 ID : 5885523443

Option 2 ID : 5885523444

Option 3 ID : 5885523441

Option 4 ID : 5885523442

Status : Answered

Chosen Option : 3

Q.3

1 The negation of " $\forall n \in N, n + 7 > 6$ " is ...Ans  1.

$$\exists n \in N, \text{ such that } n + 7 \leq 6$$

 2.

$$\exists n \in N, \text{ such that } n + 7 \geq 6$$

$$\text{X } 3. \quad \forall n \in N, n + 7 \leq 6$$

 4.

$$\exists n \in N, \text{ such that } n + 7 < 6$$

Question Type : MCQ

Question ID : 588552898

Option 1 ID : 5885523589

Option 2 ID : 5885523591

Option 3 ID : 5885523590

Option 4 ID : 5885523592

Status : Answered

Chosen Option : 1

Q.3

2 If the vectors $x\hat{i} - 3\hat{j} + 7\hat{k}$ and $\hat{i} + y\hat{j} - z\hat{k}$ are collinear then the value of $\frac{xy^2}{z}$ is equal to

Ans

$$\text{X } 1. \quad \frac{9}{7}$$

$$\text{✓ } 2. \quad \frac{-9}{7}$$

$$\text{X } 3. \quad \frac{-7}{9}$$

$$\text{X } 4. \quad \frac{7}{9}$$

Question Type : MCQ

Question ID : 588552883

Option 1 ID : 5885523532

Option 2 ID : 5885523530

Option 3 ID : 5885523529

Option 4 ID : 5885523531

Status : Answered

Chosen Option : 2

Q.3
3 If $\int \tan(x - \alpha) \tan(x + \alpha) \cdot \tan 2x \, dx = p \log |\sec 2x| + q \log |\sec(x + \alpha)| + r \log |\sec(x - \alpha)| + c$
then $p + q + r = \dots\dots$

Ans

✓ 1. $\frac{-3}{2}$

✗ 2. $\frac{-5}{2}$

✗ 3. $\frac{5}{2}$

✗ 4. $\frac{3}{2}$



Question Type : MCQ

Question ID : 588552892

Option 1 ID : 5885523566

Option 2 ID : 5885523568

Option 3 ID : 5885523567

Option 4 ID : 5885523565

Status : Answered

Chosen Option : 1

Q.3
4 Using Differentiation, approximate value of $f(x) = x^2 - 2x + 1$ at $x = 2.99$ is

Ans ✓ 1. 3.96

✗ 2. 9.96

✗ 3. 4.98

✗ 4. 5.98

Question Type : MCQ

Question ID : 588552851
Option 1 ID : 5885523401
Option 2 ID : 5885523403
Option 3 ID : 5885523402
Option 4 ID : 5885523404
Status : Answered
Chosen Option : 1

Q.3 A particle moves so that $x = 2 + 27t - t^3$. The direction of motion reverses after moving a distance of units.

- Ans
- 1. 80
 - 2. 56
 - 3. 60
 - 4. 65

Question Type : MCQ
Question ID : 588552889
Option 1 ID : 5885523556
Option 2 ID : 5885523554
Option 3 ID : 5885523555
Option 4 ID : 5885523553
Status : Marked For Review
Chosen Option : 2

Q.3
6 Which of the following is *NOT* equal to $\bar{w} \cdot (\bar{u} \times \bar{v})$?

- Ans
- 1. $\bar{u} \cdot (\bar{v} \times \bar{w})$
 - 2. $\bar{v} \cdot (\bar{w} \times \bar{u})$
 - 3. $(\bar{u} \times \bar{v}) \cdot \bar{w}$
 - 4. $\bar{v} \cdot (\bar{u} \times \bar{w})$

Question Type : MCQ
Question ID : 588552870
Option 1 ID : 5885523477
Option 2 ID : 5885523478
Option 3 ID : 5885523480
Option 4 ID : 5885523479
Status : Answered
Chosen Option : 4

Q.3
7 The value of $\sin 18^\circ$ is

Ans

1. $\frac{\sqrt{5} + 1}{4}$

2. $\frac{\sqrt{5} - 1}{4}$

3. $\frac{4}{\sqrt{5} + 1}$

4. $\frac{4}{\sqrt{5} - 1}$

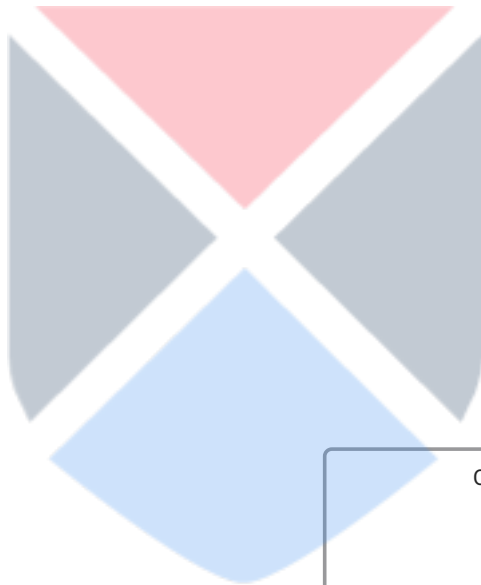

Question Type : MCQ

Question ID : 588552888

Option 1 ID : 5885523549

Option 2 ID : 5885523550

Option 3 ID : 5885523552

Option 4 ID : 5885523551

Status : Answered

Chosen Option : 2

Q.3 If the foot of the perpendicular drawn from the point (0,0,0) to the plane is (4,-2,-5) then the equation of the plane is.....

Ans 1. $4x + 2y + 5z = -13$

2. $4x - 2y - 5z = 45$

3. $4x + 2y - 5z = 37$

4. $4x - 2y + 5z = -5$

Question Type : MCQ

Question ID : 588552869

Option 1 ID : 5885523475

Option 2 ID : 5885523473

Option 3 ID : 5885523476

Option 4 ID : 5885523474

Status : Answered

Q.3
9

$$\int \frac{x^2 + 1}{x^4 - x^2 + 1} dx = \dots$$

Ans

✘ 1. $\tan^{-1} \left(\frac{x^2 + 1}{2} \right) + c$

✘ 2. $\tan^{-1}(x^2) + c$

✘ 3. $\tan^{-1}(2x^2 - 1) + c$

✔ 4. $\tan^{-1} \left(\frac{x^2 - 1}{x} \right) + c$

Question Type : MCQ

Question ID : 588552854

Option 1 ID : 5885523416

Option 2 ID : 5885523415

Option 3 ID : 5885523414

Option 4 ID : 5885523413

Status : Answered

Chosen Option : 4

Q.4
0

If $x^y = e^{x-y}$, then $\frac{dy}{dx}$ at $x = 1$ is

Ans

✘ 1. e

✘ 2. 1

✔ 3. 0

✘ 4. -1

Question Type : MCQ

Question ID : 588552855

Option 1 ID : 5885523420

Option 2 ID : 5885523417

Option 3 ID : 5885523418

Option 4 ID : 5885523419

Status : Answered

Chosen Option : 3

Q.4

1 If $A = \begin{bmatrix} 1 + 2i & i \\ -i & 1 - 2i \end{bmatrix}$, where $i = \sqrt{-1}$, then $A(\text{adj}A) = \dots\dots$

Ans 1. $-2I$

2. $2I$

3. $5I$

4. $4I$

Question Type : MCQ

Question ID : 588552872

Option 1 ID : 5885523485

Option 2 ID : 5885523486

Option 3 ID : 5885523488

Option 4 ID : 5885523487

Status : Answered

Chosen Option : 4

Q.4 Which of the following statement is contingency?

2

Ans 1. $(p \vee q) \vee \sim q$

2. $(p \vee q) \vee \sim p$

3. $(p \vee q) \wedge \sim q$

4. $p \rightarrow (p \vee q)$

Question Type : MCQ

Question ID : 588552860

Option 1 ID : 5885523438

Option 2 ID : 5885523437

Option 3 ID : 5885523440

Option 4 ID : 5885523439

Status : Answered

Chosen Option : 3

Q.4

3

$$\int_a^b \frac{\sqrt{x}}{\sqrt{x} + \sqrt{a+b-x}} dx = \dots$$

Ans 1. a+b

2. $\frac{b-a}{2}$

3. a-b

4. $\frac{a-b}{2}$

Question Type : MCQ

Question ID : 588552891

Option 1 ID : 5885523563

Option 2 ID : 5885523562

Option 3 ID : 5885523564

Option 4 ID : 5885523561

Status : Answered

Chosen Option : 2

Q.4 The intercept on the line $y = x$ by the circle $x^2 + y^2 - 2x = 0$ is AB. The equation of the circle with AB as a diameter is

Ans

1. $x^2 + y^2 + x + y = 0$

2. $x^2 + y^2 - x - y = 0$

3. $x^2 + y^2 - 3x + y = 0$

4. $x^2 + y^2 + 3x - y = 0$

Question Type : MCQ

Question ID : 588552862

Option 1 ID : 5885523445

Option 2 ID : 5885523446

Option 3 ID : 5885523447

Q.4
5 The equation of the circle concentric with the circle $x^2 + y^2 - 6x - 4y - 12 = 0$ and touching the Y-axis is

Ans  1.

$$x^2 + y^2 - 6x - 4y + 4 = 0$$

 2.

$$x^2 + y^2 - 6x - 4y + 9 = 0$$

 3.

$$x^2 + y^2 - 6x - 4y - 4 = 0$$

 4.

$$x^2 + y^2 - 6x - 4y - 9 = 0$$

Question Type : MCQ

Question ID : 588552900

Option 1 ID : 5885523600

Option 2 ID : 5885523597

Option 3 ID : 5885523599

Option 4 ID : 5885523598

Status : Answered

Chosen Option : 2

Q.4
6

$$\int_0^1 x(1-x)^5 dx = \dots$$

Ans

 1. $\frac{1}{5}$

✓^{2.} $\frac{1}{42}$

✗^{3.} $\frac{1}{13}$

✗^{4.} $\frac{13}{42}$

Question Type : MCQ

Question ID : 588552866

Option 1 ID : 5885523464

Option 2 ID : 5885523463

Option 3 ID : 5885523461

Option 4 ID : 5885523462

Status : Answered

Chosen Option : 2

Q.4
7 If $4 \sin^{-1} x + 6 \cos^{-1} x = 3\pi$ then $x = \dots\dots$

Ans

✗^{1.} $\frac{1}{\sqrt{2}}$

✗^{2.} $\frac{1}{2}$

✓^{3.0}

✗^{4.} $\frac{-1}{2}$

Question Type : MCQ

Question ID : 588552871

Option 1 ID : 5885523482
Option 2 ID : 5885523483
Option 3 ID : 5885523484
Option 4 ID : 5885523481
Status : Answered
Chosen Option : 3

Q.4
8

$$\text{If } \int_0^a \sqrt{\frac{a-x}{x}} dx = \frac{K}{2}, \text{ then } K = \dots$$

Ans

✗ 1. $\frac{\pi a}{2}$

✗ 2. $\frac{5\pi a}{2}$

✗ 3. $\frac{3\pi a}{2}$

✓ 4. πa



Question Type : MCQ
Question ID : 588552853
Option 1 ID : 5885523410
Option 2 ID : 5885523412
Option 3 ID : 5885523411
Option 4 ID : 5885523409
Status : Answered
Chosen Option : 4

Q.4
9

$$\text{In } \Delta ABC; \text{ with usual notations, } \frac{b \sin B - c \sin C}{\sin(B-C)} = \dots$$

Ans

✗ 1. b

✗ 2. $a + b + c$

✓ 3. a

~~X~~ 4. C

Question Type : MCQ

Question ID : 588552859

Option 1 ID : 5885523434

Option 2 ID : 5885523436

Option 3 ID : 5885523433

Option 4 ID : 5885523435

Status : Answered

Chosen Option : 3

Q.5
0 The solution of the differential equation $\frac{d\theta}{dt} = -k(\theta - \theta_0)$ where k is constant, is

Ans

✓ 1. $\theta = \theta_0 + ae^{-kt}$

~~X~~ 2. $\theta = \theta_0 + ae^{kt}$

~~X~~ 3. $\theta = 2\theta_0 - ae^{kt}$

~~X~~ 4. $\theta = 2\theta_0 - ae^{-kt}$

Question Type : MCQ

Question ID : 588552878

Option 1 ID : 5885523509

Option 2 ID : 5885523510

Option 3 ID : 5885523512

Option 4 ID : 5885523511

Status : Answered

Chosen Option : 1