

Telangana State Council Higher Education

Notations :

- 1.Options shown in green color and with ✓ icon are correct.
- 2.Options shown in red color and with ✗ icon are incorrect.

Question Paper Name :	Instrumentation Engineering 13th Aug 2021 Shift 1
Subject Name :	Instrumentation Engineering
Creation Date :	2021-08-13 15:04:33
Duration :	120
Total Marks :	120
Display Marks:	Yes
Calculator :	None
Magnifying Glass Required? :	No
Ruler Required? :	No
Eraser Required? :	No
Scratch Pad Required? :	No
Rough Sketch/Notepad Required? :	No
Protractor Required? :	No
Show Watermark on Console? :	Yes
Highlighter :	No
Auto Save on Console? :	Yes

Instrumentation Engineering

Group Number :	1
Group Id :	63643127
Group Maximum Duration :	0
Group Minimum Duration :	120

Show Attended Group? :	No
Edit Attended Group? :	No
Break time :	0
Group Marks :	120
Is this Group for Examiner? :	No

Mathematics

Section Id :	63643150
Section Number :	1
Section type :	Online
Mandatory or Optional :	Mandatory
Number of Questions :	10
Number of Questions to be attempted :	10
Section Marks :	10
Enable Mark as Answered Mark for Review and Clear Response :	Yes
Sub-Section Number :	1
Sub-Section Id :	63643150
Question Shuffling Allowed :	Yes

Question Number : 1 Question Id : 6364313121 Question Type : MCQ Option Shuffling : Yes Display Question Number : Yes Is Question Mandatory : No Option Orientation : Vertical Correct Marks : 1 Wrong Marks : 0

One of the eigen values of the matrix $\begin{bmatrix} 3 & -4 & 5 \\ -4 & 5 & 3 \\ 5 & 3 & -4 \end{bmatrix}$ is

Options :

1. ✘ 1

2. ✘ 2

3. ✘ 3

4. ✔ 4

Question Number : 2 Question Id : 6364313122 Question Type : MCQ Option Shuffling : Yes Display Question Number : Yes Is Question Mandatory : No Option Orientation : Vertical

Correct Marks : 1 Wrong Marks : 0

The nullity of the matrix $\begin{bmatrix} 3 & 6 & 9 \\ 1 & 2 & 4 \\ 2 & 4 & 6 \end{bmatrix}$ is

Options :

1. ✔ 1

2. ✘ 2

3. ✘ 3

4. ✘ 0

Question Number : 3 Question Id : 6364313123 Question Type : MCQ Option Shuffling : Yes Display Question Number : Yes Is Question Mandatory : No Option Orientation : Vertical

Correct Marks : 1 Wrong Marks : 0

Consider $f(x) = e^{-x} \sin x$, $x \in [0, \pi]$. Using Rolle's theorem we get a $c \in (0, \pi)$ which is a solution of the equation

Options :

1. ✘ $\cos x = 1$

2. ✔ $\tan x = 1$

3. ✘ $\cot x = -1$

4. ✘ $\sin x = 1$

Question Number : 4 Question Id : 6364313124 Question Type : MCQ Option Shuffling : Yes Display Question Number : Yes Is Question Mandatory : No Option Orientation : Vertical

Correct Marks : 1 Wrong Marks : 0

$$\int_0^{\pi/2} \int_0^{\pi/2} \cos(x + 2y) dy dx =$$

Options :

1. ✘ -3

2. ✘ -2

3. ✔ -1

4. ✘ 0

Question Number : 5 Question Id : 6364313125 Question Type : MCQ Option Shuffling : Yes Display Question Number : Yes Is Question Mandatory : No Option Orientation : Vertical Correct Marks : 1 Wrong Marks : 0

The solution of $y'' + y' = e^{-x}$ satisfying $y(0) = 0$ and $y'(0) = -1$ is

Options :

1. ✘ $y = xe^{-x}$

2. ✘ $y = 2xe^{-x}$

3. ✘ $y = -2xe^{-x}$

4. ✔ $y = -xe^{-x}$

Question Number : 6 Question Id : 6364313126 Question Type : MCQ Option Shuffling : Yes Display Question Number : Yes Is Question Mandatory : No Option Orientation : Vertical Correct Marks : 1 Wrong Marks : 0

The particular integral of $\frac{\partial^2 z}{\partial x^2} - 2\frac{\partial^2 z}{\partial x \partial y} + \frac{\partial^2 z}{\partial y^2} = e^{x-y}$ is

Options :

1. ✓ $\frac{1}{6}e^{x-y}$

2. ✗ $\frac{1}{4}e^{x-y}$

3. ✗ $\frac{1}{3}e^{x-y}$

4. ✗ $\frac{1}{2}e^{x-y}$

Question Number : 7 Question Id : 6364313127 Question Type : MCQ Option Shuffling : Yes Display Question Number : Yes Is Question Mandatory : No Option Orientation : Vertical Correct Marks : 1 Wrong Marks : 0

$$\int_{|z|=2} \frac{z}{z^2+1} dz =$$

Options :

1. ✘ $\frac{1}{2}\pi i$

2. ✔ $2\pi i$

3. ✘ $\frac{1}{3}\pi i$

4. ✘ $\frac{1}{4}\pi i$

Question Number : 8 Question Id : 6364313128 Question Type : MCQ Option Shuffling : Yes Display Question Number : Yes Is Question Mandatory : No Option Orientation : Vertical

Correct Marks : 1 Wrong Marks : 0

Iterative formula to find the value of $\frac{1}{\sqrt{N}}$ by Newton Raphson method is

Options :

1. ✘ $x_{n+1} = \frac{1}{2} \left[x_n - \frac{1}{Nx_n} \right]$

2. ✘ $x_{n+1} = \frac{1}{2} \left[Nx_n - \frac{1}{N} \right]$

3. ✓
$$x_{n+1} = \frac{1}{2} \left[x_n + \frac{1}{Nx_n} \right]$$

4. ✗
$$x_{n+1} = \frac{1}{2} \left[Nx_n + \frac{1}{N} \right]$$

Question Number : 9 Question Id : 6364313129 Question Type : MCQ Option Shuffling : Yes Display Question Number : Yes Is Question Mandatory : No Option Orientation : Vertical

Correct Marks : 1 Wrong Marks : 0

A bag contains 11 blue balls and 13 green balls two balls are drawn at random.
Then the probability that the two balls are of same color is

Options :

1. ✗
$$\frac{134}{300}$$

2. ✓
$$\frac{133}{300}$$

3. ✗
$$\frac{132}{300}$$

4. ✗
$$\frac{131}{300}$$

Question Number : 10 Question Id : 6364313130 Question Type : MCQ Option Shuffling : Yes Display Question Number : Yes Is Question Mandatory : No Option Orientation : Vertical Correct Marks : 1 Wrong Marks : 0

If two persons A and B toss an unbiased coin alternatively on the understanding that the first who gets the head wins, then the winning chances of A is

Options :

1. $\frac{1}{4}$
2. $\frac{3}{4}$
3. $\frac{1}{3}$
4. $\frac{2}{3}$

Instrumentation Engineering

Section Id :	63643151
Section Number :	2
Section type :	Online
Mandatory or Optional :	Mandatory
Number of Questions :	110

Number of Questions to be attempted : 110
Section Marks : 110
Enable Mark as Answered Mark for Review and Clear Response : Yes
Sub-Section Number : 1
Sub-Section Id : 63643151
Question Shuffling Allowed : Yes

Question Number : 11 Question Id : 6364313131 Question Type : MCQ Option Shuffling : Yes Display Question Number : Yes Is Question Mandatory : No Option Orientation : Vertical
Correct Marks : 1 Wrong Marks : 0

In the given circuit, the values of V_1 and V_2 respectively are

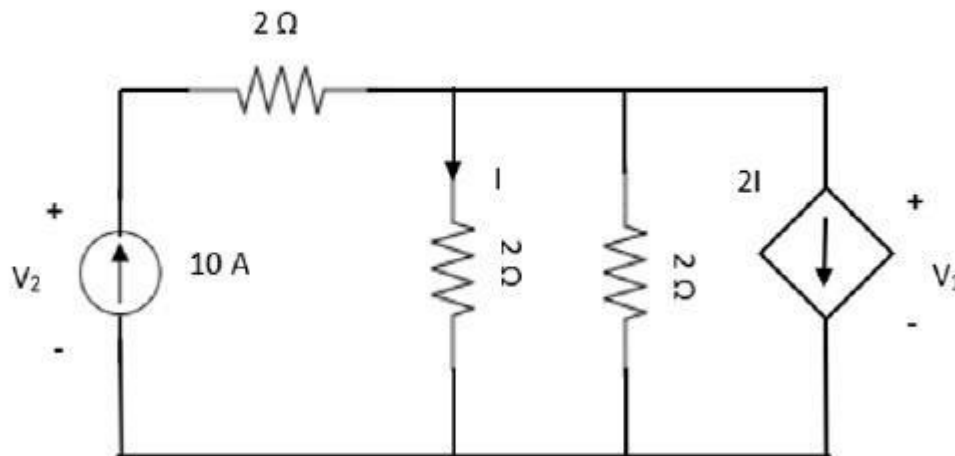

Options :

1. ✓ 5V, 25V
2. ✗ 10V, 30V
3. ✗ 15V, 35V

4. ✘ 0V, 20V

Question Number : 12 Question Id : 6364313132 Question Type : MCQ Option Shuffling : Yes Display Question Number : Yes Is Question Mandatory : No Option Orientation : Vertical Correct Marks : 1 Wrong Marks : 0

The circuit shown in the figure represents a

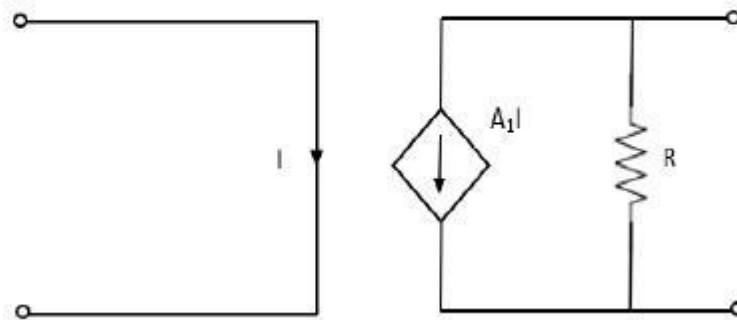

Options :

1. ✘ voltage controlled voltage source
2. ✘ voltage controlled current source
3. ✔ current controlled current source
4. ✘ current controlled voltage source

Question Number : 13 Question Id : 6364313133 Question Type : MCQ Option Shuffling : Yes Display Question Number : Yes Is Question Mandatory : No Option Orientation : Vertical Correct Marks : 1 Wrong Marks : 0

Consider a delta connection of resistors and its equivalent star connection. If all elements of the delta connection are scaled by a factor K , $K > 0$, the elements of the corresponding star equivalent will be scaled by a factor of

Options :

1. ✘ K^2
2. ✔ K
3. ✘ $1/K$
4. ✘ $K^{(1/2)}$

Question Number : 14 Question Id : 6364313134 Question Type : MCQ Option Shuffling : Yes Display Question Number : Yes Is Question Mandatory : No Option Orientation : Vertical Correct Marks : 1 Wrong Marks : 0

Norton's theorem states that the complex network connected to a load can be replaced with an equivalent impedance

Options :

1. ✘ In series with a current source

2. ✘ In parallel with a voltage source
3. ✘ In series with a voltage source
4. ✔ In parallel with a current source

Question Number : 15 Question Id : 6364313135 Question Type : MCQ Option Shuffling : Yes Display Question Number : Yes Is Question Mandatory : No Option Orientation : Vertical Correct Marks : 1 Wrong Marks : 0

If each branch of a Delta circuit has impedance $\sqrt{3} Z$, then each branch of the equivalent star circuit has impedance

Options :

1. ✔ $\frac{Z}{\sqrt{3}}$
2. ✘ $3 Z$
3. ✘ $3\sqrt{3} Z$
4. ✘ $\frac{Z}{3}$

Question Number : 16 Question Id : 6364313136 Question Type : MCQ Option Shuffling : Yes Display Question Number : Yes Is Question Mandatory : No Option Orientation : Vertical Correct Marks : 1 Wrong Marks : 0

The current flowing through an impedance of $(4 - j6) \Omega$ connected to a circuit is $5\cos(100\pi t + 100)$ A. The average power delivered to the impedance is

Options :

1. ✘ 44.2 W
2. ✔ 50 W
3. ✘ 62.5 W
4. ✘ 125 W

Question Number : 17 Question Id : 6364313137 Question Type : MCQ Option Shuffling : Yes Display Question Number : Yes Is Question Mandatory : No Option Orientation : Vertical Correct Marks : 1 Wrong Marks : 0

Consider the configuration in the figure which is a portion of a larger electrical network.

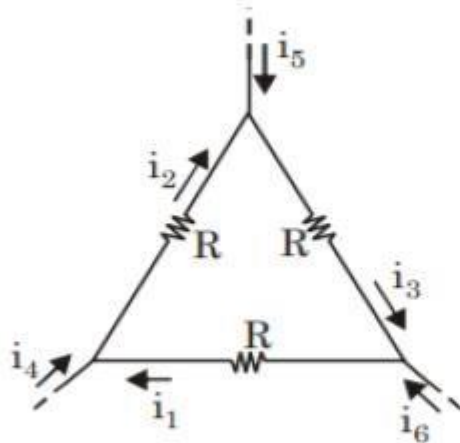

For $R=1\Omega$ and currents $i_1 = 2A$, $i_4 = -1A$, $i_5 = -4A$, which one of the following is TRUE?

Options :

1. ✓ $i_6 = 5A$

2. ✗ $i_3 = -4A$

3. ✗ Data is sufficient to conclude that the supposed currents are impossible.

4. ✗ Data is insufficient to identify the currents i_2 , i_3 and i_6

Question Number : 18 Question Id : 6364313138 Question Type : MCQ Option Shuffling : Yes Display Question Number : Yes Is Question Mandatory : No Option Orientation : Vertical Correct Marks : 1 Wrong Marks : 0

The equivalent inductance measured between the terminals 1 and 2 for the circuit shown in the figure is

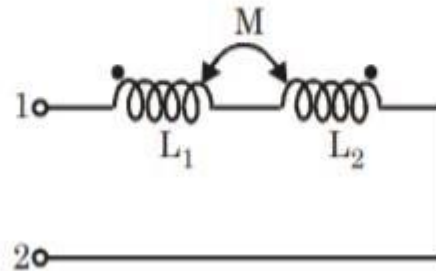

Options :

1. ✘ $L_1 + L_2 + M$
2. ✘ $L_1 + L_2 - M$
3. ✘ $L_1 + L_2 + 2M$
4. ✔ $L_1 + L_2 - 2M$

Question Number : 19 Question Id : 6364313139 Question Type : MCQ Option Shuffling : Yes Display Question Number : Yes Is Question Mandatory : No Option Orientation : Vertical Correct Marks : 1 Wrong Marks : 0

A fully charged mobile phone with a 12 V battery is good for a 20-minute talk-time. Assume that, during the talk-time, the battery delivers a constant current of a 2 A and its voltage drops linearly from 12 V to 0 V as shown in the figure. How much energy does the battery deliver during this talk-time

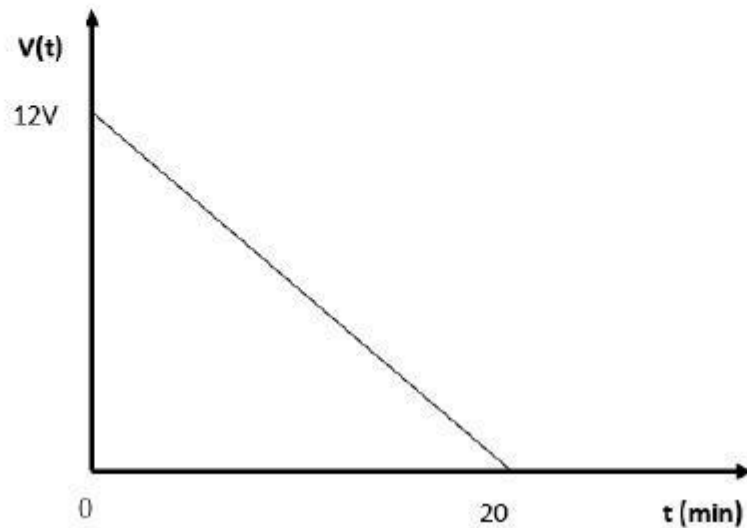

Options :

1. ✘ 140 KJ
2. ✘ 12 KJ
3. ✔ 14.4 KJ

4. ✘ 240 KJ

Question Number : 20 Question Id : 6364313140 Question Type : MCQ Option Shuffling : Yes Display Question Number : Yes Is Question Mandatory : No Option Orientation : Vertical Correct Marks : 1 Wrong Marks : 0

The power delivered or absorbed by the dependent current source shown in given figure is

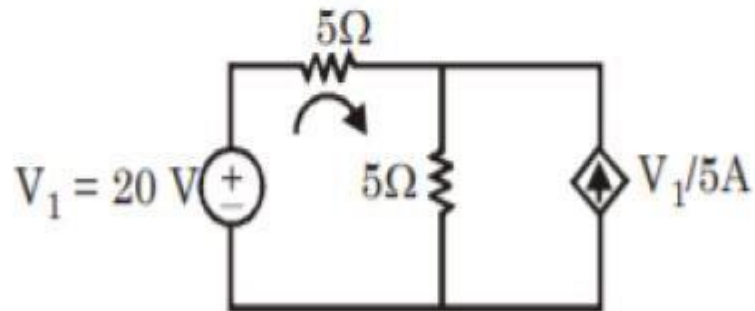

Options :

1. ✔ Delivers 80 W
2. ✘ Absorbs 80 W
3. ✘ Delivers 40 W
4. ✘ Absorbs 40 W

Question Number : 21 Question Id : 6364313141 Question Type : MCQ Option Shuffling : Yes Display Question Number : Yes Is Question Mandatory : No Option Orientation : Vertical Correct Marks : 1 Wrong Marks : 0

The primary and secondary of an LVDT (stroke length ± 50 mm) are connected to a 3kHz sinusoidal source and ideal semiconductor diode bridge-based phase sensitive demodulator circuit. The core of the LVDT remains static at 15 mm above the ideal null position. The frequency of the voltage observed at the input of the low-pass filter is

Options :

1. ✘ 1 kHz
2. ✘ 1.5 kHz
3. ✔ 3 kHz
4. ✘ 6 kHz

Question Number : 22 Question Id : 6364313142 Question Type : MCQ Option Shuffling : Yes Display Question Number : Yes Is Question Mandatory : No Option Orientation : Vertical Correct Marks : 1 Wrong Marks : 0

Thermistor whose resistance decreases with increasing temperature is

Options :

1. ✘ PTC thermistors
2. ✘ Sensistors
3. ✘ RTD
4. ✔ NTC thermistors

Question Number : 23 Question Id : 6364313143 Question Type : MCQ Option Shuffling : Yes Display Question Number : Yes Is Question Mandatory : No Option Orientation : Vertical Correct Marks : 1 Wrong Marks : 0

In a gas chromatograph, the gas which cannot be used as a carrier gas is

Options :

1. ✘ Helium
2. ✘ Nitrogen
3. ✔ Oxygen
4. ✘ Hydrogen

Question Number : 24 Question Id : 6364313144 Question Type : MCQ Option Shuffling : Yes Display Question Number : Yes Is Question Mandatory : No Option Orientation : Vertical

Correct Marks : 1 Wrong Marks : 0

The temperature transmitter has a range of $(0-500)^{\circ}\text{C}$ and provides $(4-20)$ mA current output. The measured temperature and the output current have a straight-line relationship with positive slope. The temperature is determined from the voltage measured across a resistance of $500\ \Omega$ in the current loop. If the voltage measured across the resistance is $4\ \text{V}$, the temperature of the furnace is

Options :

1. ✘ 100°C
2. ✔ 125°C
3. ✘ 150°C
4. ✘ 200°C

Question Number : 25 Question Id : 6364313145 Question Type : MCQ Option Shuffling : Yes Display Question Number : Yes Is

Question Mandatory : No Option Orientation : Vertical

Correct Marks : 1 Wrong Marks : 0

Among the bonded metal strain gauges, the foil type is more popular than the wire type because

Options :

1. ✘ error due to transverse strain is much less
2. ✘ gauge factor is much higher
3. ✔ more insensitive to temperature variation
4. ✘ more sensitive to temperature variation

Question Number : 26 Question Id : 6364313146 Question Type : MCQ Option Shuffling : Yes Display Question Number : Yes Is Question Mandatory : No Option Orientation : Vertical Correct Marks : 1 Wrong Marks : 0

The capacitance of a capacitor is

Options :

1. ✘ Inversely proportional to the area of the plates
2. ✔ Directly proportional to the area of the plates
3. ✘ Proportional to the square of area of the plates
4. ✘ Proportional to the square root of area of the plates

Question Number : 27 Question Id : 6364313147 Question Type : MCQ Option Shuffling : Yes Display Question Number : Yes Is Question Mandatory : No Option Orientation : Vertical

Correct Marks : 1 Wrong Marks : 0

A signal conditioning circuit suitable for a push-pull type capacitive transducer is given in Figure. The output V_0 is

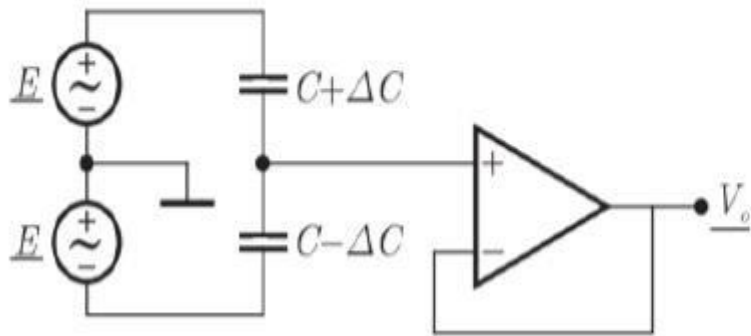

Options :

1. ✓ $V_0 = E \frac{\Delta C}{C}$
2. ✗ $V_0 = E \frac{C}{\Delta C}$
3. ✗ $V_0 = E \frac{C - \Delta C}{C + \Delta C}$
4. ✗ $V_0 = E \frac{C + \Delta C}{C - \Delta C}$

Question Number : 28 Question Id : 6364313148 Question Type : MCQ Option Shuffling : Yes Display Question Number : Yes Is Question Mandatory : No Option Orientation : Vertical Correct Marks : 1 Wrong Marks : 0

_____ provides additional strength and prevents an optical fiber from any damage.

Options :

1. ✘ Core
2. ✘ Cladding
3. ✔ Buffer coating
4. ✘ Optical Detector

Question Number : 29 Question Id : 6364313149 Question Type : MCQ Option Shuffling : Yes Display Question Number : Yes Is Question Mandatory : No Option Orientation : Vertical Correct Marks : 1 Wrong Marks : 0

The pH value of a solution is 4. It indicates that concentration of hydrogen ions is

Options :

1. ✔ 10^{-4} g/L and the solution is acidic
2. ✘ 10^{-4} g/L and the solution is alkaline
3. ✘ 10^{-4} mg/L and the solution is acidic

4. ✘ 10^{-4} mg/L and the solution is alkaline

Question Number : 30 Question Id : 6364313150 Question Type : MCQ Option Shuffling : Yes Display Question Number : Yes Is Question Mandatory : No Option Orientation : Vertical Correct Marks : 1 Wrong Marks : 0

For flow measurement, a rotameter can be installed in a pipe line

Options :

1. ✘ Horizontally with flow inlet in a specific direction
2. ✘ Horizontally with flow inlet in any direction
3. ✔ Vertically with flow inlet at the bottom and the outlet at the top
4. ✘ Vertically with flow inlet at the top and outlet at the bottom

Question Number : 31 Question Id : 6364313151 Question Type : MCQ Option Shuffling : Yes Display Question Number : Yes Is Question Mandatory : No Option Orientation : Vertical Correct Marks : 1 Wrong Marks : 0

Which flow meter have higher accuracy among the following

Options :

1. ✔ Turbine flowmeter

2. ✘ Ultrasonic flowmeter
3. ✘ Vortex flowmeter
4. ✘ Venturi meter

Question Number : 32 Question Id : 6364313152 Question Type : MCQ Option Shuffling : Yes Display Question Number : Yes Is Question Mandatory : No Option Orientation : Vertical Correct Marks : 1 Wrong Marks : 0

The order of a temperature measuring system formed by a thermocouple with a thermal well is

Options :

1. ✔ Second order
2. ✘ Zero order
3. ✘ Third order
4. ✘ First order

Question Number : 33 Question Id : 6364313153 Question Type : MCQ Option Shuffling : Yes Display Question Number : Yes Is Question Mandatory : No Option Orientation : Vertical

Correct Marks : 1 Wrong Marks : 0

The platinum RTD has

Options :

1. ✘ Negative temperature coefficient of resistance
2. ✔ Positive temperature coefficient of resistance
3. ✘ Positive and negative temperature coefficient of resistance
4. ✘ Highly non-linear characteristics

Question Number : 34 Question Id : 6364313154 Question Type : MCQ Option Shuffling : Yes Display Question Number : Yes Is

Question Mandatory : No Option Orientation : Vertical

Correct Marks : 1 Wrong Marks : 0

A seismic type of transducer has damping constant of 10. The transducer is designed to measure

Options :

1. ✔ Acceleration
2. ✘ Velocity
3. ✘ Displacement

4. ✘ Force

Question Number : 35 Question Id : 6364313155 Question Type : MCQ Option Shuffling : Yes Display Question Number : Yes Is Question Mandatory : No Option Orientation : Vertical Correct Marks : 1 Wrong Marks : 0

In the case of a variable reluctance type inductive transducer, push-pull arrangement reduces non-linearity by eliminating

Options :

1. ✘ The odd order harmonics
2. ✘ The even order harmonics
3. ✘ Both odd and even harmonics
4. ✔ Offset

Question Number : 36 Question Id : 6364313156 Question Type : MCQ Option Shuffling : Yes Display Question Number : Yes Is Question Mandatory : No Option Orientation : Vertical Correct Marks : 1 Wrong Marks : 0

A thermocouple is suddenly immersed in a medium of high temperature. The approximate time taken by the thermocouple to reach 98% of the steady state value is

Options :

1. ✘ Equal to the time constant of the thermocouple
2. ✘ Equal to twice the value of the time constant of the thermocouple
3. ✔ Equal to four times the value of the time constant of the thermocouple
4. ✘ Independent of the time constant

Question Number : 37 Question Id : 6364313157 Question Type : MCQ Option Shuffling : Yes Display Question Number : Yes Is Question Mandatory : No Option Orientation : Vertical Correct Marks : 1 Wrong Marks : 0

An N-type semiconductor strain gauge has a nominal resistance of 1000Ω and gauge factor of -100 , when a compressive strain of $100 \mu\text{m/m}$ is applied the resistance of the gauge is

Options :

1. ✘ 900Ω
2. ✔ 990Ω
3. ✘ 1010Ω

4. ✘ 1100 Ω

Question Number : 38 Question Id : 6364313158 Question Type : MCQ Option Shuffling : Yes Display Question Number : Yes Is Question Mandatory : No Option Orientation : Vertical Correct Marks : 1 Wrong Marks : 0

Poisson's ratio for a metal is 0.35 neglecting piezo-resistance effect, the gauge factor of a strain gauge made of this metal is

Options :

1. ✘ 0.65

2. ✘ 1

3. ✘ 1.35

4. ✔ 1.70

Question Number : 39 Question Id : 6364313159 Question Type : MCQ Option Shuffling : Yes Display Question Number : Yes Is Question Mandatory : No Option Orientation : Vertical Correct Marks : 1 Wrong Marks : 0

Consider the thermocouple whose reference junction is at 0°C and sensitivity is $52.68 \mu\text{V}/^{\circ}\text{C}$. The measured output voltage at 300°C is $16325 \mu\text{V}$. What is the difference between measured value and true value

Options :

1. ✓ $521 \mu\text{V}$
2. ✗ $16325 \mu\text{V}$
3. ✗ $15804 \mu\text{V}$
4. ✗ $1042 \mu\text{V}$

Question Number : 40 Question Id : 6364313160 Question Type : MCQ Option Shuffling : Yes Display Question Number : Yes Is Question Mandatory : No Option Orientation : Vertical Correct Marks : 1 Wrong Marks : 0

The figure below shows various configuration of bonding a strain gauge to a cantilever subjected to a bending force F .

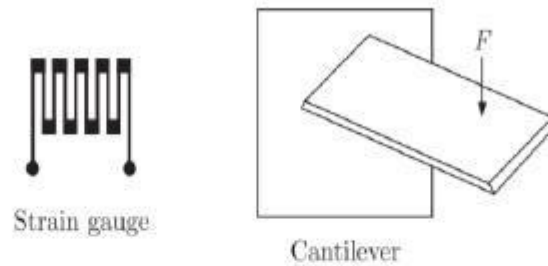

Top views of possible configurations

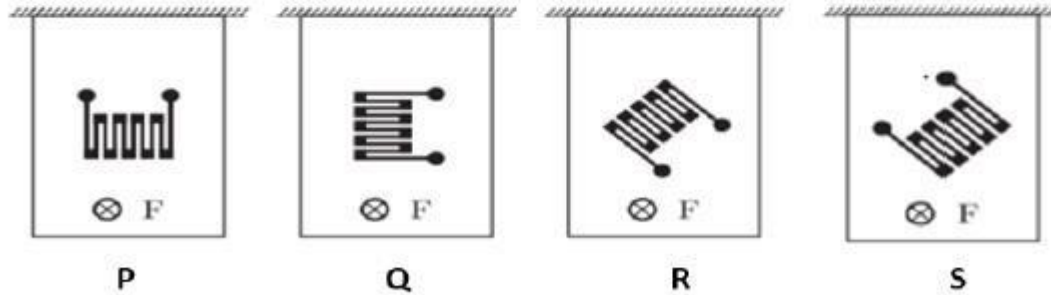

Which configuration given the maximum change in resistance for this force

Options :

1. ✘ P

2. ✔ Q

3. ✘ R

4. ✘ S

Question Number : 41 Question Id : 6364313161 Question Type : MCQ Option Shuffling : Yes Display Question Number : Yes Is Question Mandatory : No Option Orientation : Vertical Correct Marks : 1 Wrong Marks : 0

If both inputs of an ideal Opamp in comparator configuration is fed with same voltage, then the output is

Options :

1. ✘ Equal to the positive supply voltage

2. ✔ Equal to zero

3. ✘ Equal to CMRR

4. ✘ Equal to the negative supply voltage

Question Number : 42 Question Id : 6364313162 Question Type : MCQ Option Shuffling : Yes Display Question Number : Yes Is Question Mandatory : No Option Orientation : Vertical Correct Marks : 1 Wrong Marks : 0

The phase difference between the input and output voltages in a common base arrangement is

Options :

1. ✘ 180°
2. ✘ 90°
3. ✘ 270°
4. ✔ 0°

Question Number : 43 Question Id : 6364313163 Question Type : MCQ Option Shuffling : Yes Display Question Number : Yes Is Question Mandatory : No Option Orientation : Vertical

Correct Marks : 1 Wrong Marks : 0

A noninverting amplifier has R_{in} of $10\text{ K}\Omega$ and R_f of $1000\text{ K}\Omega$. The closed-loop voltage gain is

Options :

1. ✘ -101
2. ✘ -100
3. ✔ 101

4. ✘ 100

Question Number : 44 Question Id : 6364313164 Question Type : MCQ Option Shuffling : Yes Display Question Number : Yes Is Question Mandatory : No Option Orientation : Vertical Correct Marks : 1 Wrong Marks : 0

The numerical aperture of an optical fiber with core refractive index 1.5 and cladding refractive index 1.2 is _____.

Options :

1. ✔ 0.9

2. ✘ 1.2

3. ✘ 1.92

4. ✘ 1.5

Question Number : 45 Question Id : 6364313165 Question Type : MCQ Option Shuffling : Yes Display Question Number : Yes Is Question Mandatory : No Option Orientation : Vertical Correct Marks : 1 Wrong Marks : 0

If the α of BJT is 0.9 then the β is

Options :

1. ✘ 0.9

2. ✓ 9

3. ✗ 90

4. ✗ 91

Question Number : 46 Question Id : 6364313166 Question Type : MCQ Option Shuffling : Yes Display Question Number : Yes Is

Question Mandatory : No Option Orientation : Vertical

Correct Marks : 1 Wrong Marks : 0

Calculate the rectification efficiency of a halfwave rectifier with input AC power

100 Watts and DC output power 40 Watts.

Options :

1. ✗ 100%

2. ✗ 60%

3. ✓ 40%

4. ✗ 63.33%

Question Number : 47 Question Id : 6364313167 Question Type : MCQ Option Shuffling : Yes Display Question Number : Yes Is

Question Mandatory : No Option Orientation : Vertical

Correct Marks : 1 Wrong Marks : 0

The voltage gain of an amplifier without feedback is 100. If a negative feedback is introduced with a feedback fraction $\beta = 0.01$, then the gain of the feedback amplifier is

Options :

1. ✘ 100
2. ✘ 50.9
3. ✘ 90.9
4. ✔ 50

Question Number : 48 Question Id : 6364313168 Question Type : MCQ Option Shuffling : Yes Display Question Number : Yes Is Question Mandatory : No Option Orientation : Vertical Correct Marks : 1 Wrong Marks : 0

A differential amplifier has a differential gain of 20,000 $CMRR = 80dB$. The common mode gain is given by

Options :

1. ✔ 2
2. ✘ 1

3. ✘ $\frac{1}{2}$

4. ✘ 0

Question Number : 49 Question Id : 6364313169 Question Type : MCQ Option Shuffling : Yes Display Question Number : Yes Is Question Mandatory : No Option Orientation : Vertical Correct Marks : 1 Wrong Marks : 0

An amplifier has an input power of 2 mW. The power gain of the amplifier is 60dB. The output power will be

Options :

1. ✘ 6 microwatts

2. ✘ 120 microwatts

3. ✘ 2 milliwatts

4. ✔ 2 watts

Question Number : 50 Question Id : 6364313170 Question Type : MCQ Option Shuffling : Yes Display Question Number : Yes Is Question Mandatory : No Option Orientation : Vertical Correct Marks : 1 Wrong Marks : 0

The upper and lower cut-off frequencies of individual stages of a two-stage cascaded amplifier are,

Options :

$$f_{Un} = f_{U*} \sqrt{(2^{\frac{1}{n}} - 1)} \quad \text{and} \quad f_{Ln} = \frac{f_L}{\sqrt{(2^{\frac{1}{n}} - 1)}}$$

1. ✘

$$f_{Un} = \frac{f_U}{\sqrt{(2^{\frac{1}{n}} - 1)}} \quad \text{and} \quad f_{Ln} = f_{L*} \sqrt{(2^{\frac{1}{n}} - 1)}$$

2. ✔

$$f_{Un} = f_{U*} \sqrt{(2^{\frac{1}{n}} - 1)} \quad \text{and} \quad f_{Ln} = f_{L*} \sqrt{(2^{\frac{1}{n}} - 1)}$$

3. ✘

$$f_{Un} = \frac{f_U}{\sqrt{(2^{\frac{1}{n}} - 1)}} \quad \text{and} \quad f_{Ln} = \frac{f_L}{\sqrt{(2^{\frac{1}{n}} - 1)}}$$

4. ✘

Question Number : 51 Question Id : 6364313171 Question Type : MCQ Option Shuffling : Yes Display Question Number : Yes Is

Question Mandatory : No Option Orientation : Vertical

Correct Marks : 1 Wrong Marks : 0

In a CMOS logic circuit, the p-MOS transistor acts as

Options :

1. ✘ Pull down network
2. ✔ Pull up network
3. ✘ Load
4. ✘ Short to ground

Question Number : 52 Question Id : 6364313172 Question Type : MCQ Option Shuffling : Yes Display Question Number : Yes Is Question Mandatory : No Option Orientation : Vertical Correct Marks : 1 Wrong Marks : 0

The figure of merit of a logic gate family is given by

Options :

1. ✘ gain \times bandwidth
2. ✔ propagation delay \times power dissipation
3. ✘ fan-out \times propagation delay time
4. ✘ noise margin \times power dissipation

Question Number : 53 Question Id : 6364313173 Question Type : MCQ Option Shuffling : Yes Display Question Number : Yes Is Question Mandatory : No Option Orientation : Vertical

Correct Marks : 1 Wrong Marks : 0

How many flip-flops are required to build a binary counter circuit to count from 0 to 2047

Options :

1. ✘ 10
2. ✘ 6
3. ✔ 11
4. ✘ 12

Question Number : 54 Question Id : 6364313174 Question Type : MCQ Option Shuffling : Yes Display Question Number : Yes Is Question Mandatory : No Option Orientation : Vertical Correct Marks : 1 Wrong Marks : 0

Determine the loss in dB when a signal of strength 200 mV injects into an optical fiber and ejects the fiber with strength 100 mV.

Options :

1. ✘ $20 \log (200/100)$
2. ✘ $10 \log (100/200)$
3. ✘ $20 \log (100/200)$

4. ✓ $10 \log (200/100)$

Question Number : 55 Question Id : 6364313175 Question Type : MCQ Option Shuffling : Yes Display Question Number : Yes Is Question Mandatory : No Option Orientation : Vertical Correct Marks : 1 Wrong Marks : 0

Select the incorrect expression from the following

Options :

1. ✓ $X + \bar{X}Y = X$

2. ✗ $X + X\bar{Y} = X$

3. ✗ $X(Y + \bar{X}) = XY$

4. ✗ $ZX + Z\bar{X}Y = ZX + ZY$

Question Number : 56 Question Id : 6364313176 Question Type : MCQ Option Shuffling : Yes Display Question Number : Yes Is Question Mandatory : No Option Orientation : Vertical Correct Marks : 1 Wrong Marks : 0

In combinational circuit the output depends on the

Options :

1. ✓ Input combination at that time

2. ✘ Input combination and the previous output
3. ✘ Input combination at that time and the previous input combination
4. ✘ Present output and the previous output

Question Number : 57 Question Id : 6364313177 Question Type : MCQ Option Shuffling : Yes Display Question Number : Yes Is Question Mandatory : No Option Orientation : Vertical Correct Marks : 1 Wrong Marks : 0

A multiplexer is a logic circuit that

Options :

1. ✘ Accepts one input and gives several outputs
2. ✘ Accepts many inputs and gives many outputs
3. ✔ Accepts many inputs and give one output

4. ✘ Accepts one input and give one output

Question Number : 58 Question Id : 6364313178 Question Type : MCQ Option Shuffling : Yes Display Question Number : Yes Is Question Mandatory : No Option Orientation : Vertical Correct Marks : 1 Wrong Marks : 0

If a light travel in a certain medium and it gets reflected off an optically denser medium with high refractive index, then it is regarded as _____

Options :

1. ✔ External Reflection
2. ✘ Internal Reflection
3. ✘ External Refraction
4. ✘ Internal Refraction

Question Number : 59 Question Id : 6364313179 Question Type : MCQ Option Shuffling : Yes Display Question Number : Yes Is Question Mandatory : No Option Orientation : Vertical Correct Marks : 1 Wrong Marks : 0

The minimum number of comparators required in a 7-bit flash type A/D converter is

Options :

1. ✘ 128

2. 127
3. 8
4. 7

Question Number : 60 Question Id : 6364313180 Question Type : MCQ Option Shuffling : Yes Display Question Number : Yes Is Question Mandatory : No Option Orientation : Vertical Correct Marks : 1 Wrong Marks : 0

A 10-bit DAC has a step size of 20 mV. What is its full-scale output voltage?

Options :



1. 200 V
2. 204.6 V
3. 20.46 V
4. 20 V

Question Number : 61 Question Id : 6364313181 Question Type : MCQ Option Shuffling : Yes Display Question Number : Yes Is Question Mandatory : No Option Orientation : Vertical Correct Marks : 1 Wrong Marks : 0

In a microprocessor, the program counter holds







Options :

1.  The number of programs being executed on the microprocessor
2. The number of instructions being executed on the microprocessor
3.  The number of interrupts handled by the microprocessor
4.  The address of the next instruction to be fetched

Question Number : 62 Question Id : 6364313182 Question Type : MCQ Option Shuffling : Yes Display Question Number : Yes Is Question Mandatory : No Option Orientation : Vertical Correct Marks : 1 Wrong Marks : 0

In JK flip-flop if $K=J$, then it acts as

Options :

1.  SR flip-flop
2.  JK flip-flop
3.  T flip-flop
4.  D flip-flop



**Question Number : 63 Question Id : 6364313183 Question Type : MCQ Option Shuffling : Yes Display Question Number : Yes Is
Question Mandatory : No Option Orientation : Vertical
Correct Marks : 1 Wrong Marks : 0**

With a 200 kHz clock frequency, eight bits can be serially entered into a shift register in

Options :

1. ✘ 4 μ s
2. ✔ 40 μ s
3. ✘ 400 μ s
4. ✘ 40 ms

Question Number : 64 Question Id : 6364313184 Question Type : MCQ Option Shuffling : Yes Display Question Number : Yes Is Question Mandatory : No Option Orientation : Vertical Correct Marks : 1 Wrong Marks : 0

A 4 X 1 MUX is used to implement a 3 input Boolean function as shown below. The Boolean function $F(A,B,C)$ implemented is

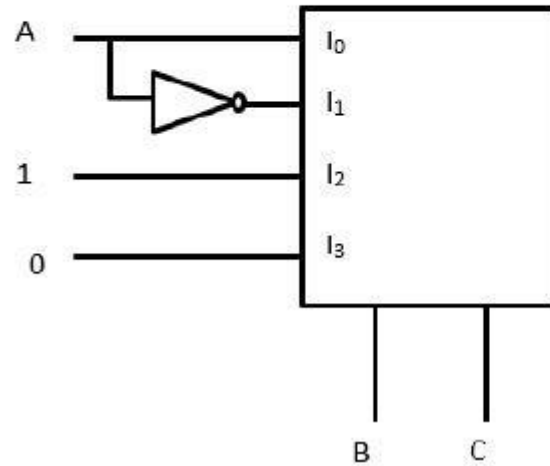

Options :

1. ✓ $F(A,B,C) = \sum(1,2,4,6)$
2. ✗ $F(A,B,C) = \sum(1,2,6)$
3. ✗ $F(A,B,C) = \sum(2,4,5,6)$
4. ✗ $F(A,B,C) = \sum(1,5,6)$

Question Number : 65 Question Id : 6364313185 Question Type : MCQ Option Shuffling : Yes Display Question Number : Yes Is Question Mandatory : No Option Orientation : Vertical Correct Marks : 1 Wrong Marks : 0

The binary equivalent of $(11.6275)_{10}$ is

Options :

1. ✘ 101.11011
2. ✔ 1011.1010
3. ✘ 101.0011
4. ✘ 1011.0011

Question Number : 66 Question Id : 6364313186 Question Type : MCQ Option Shuffling : Yes Display Question Number : Yes Is Question Mandatory : No Option Orientation : Vertical Correct Marks : 1 Wrong Marks : 0

Find the Z-transform of $a^n u(n)$; $a > 0$.

Options :

1. ✘ $\frac{1}{(1-az)}$
2. ✘ $\frac{1}{(1+az)}$

3. ✘ $\frac{z}{(z+a)}$

4. ✔ $\frac{z}{(z-a)}$

Question Number : 67 Question Id : 6364313187 Question Type : MCQ Option Shuffling : Yes Display Question Number : Yes Is Question Mandatory : No Option Orientation : Vertical Correct Marks : 1 Wrong Marks : 0

Fourier transform of the signal $x(t) = e^{-2t} u(t - 3)$ is

Options :

1. ✘ $\frac{e^{-3(2-j\omega)}}{(2-j\omega)}$

2. ✘ $\frac{e^{3(2-j\omega)}}{(2-j\omega)}$

3. ✘ $\frac{e^{3(2+j\omega)}}{(2+j\omega)}$

4. ✓
$$\frac{e^{-2(2+jw)}}{(2+jw)}$$

Question Number : 68 Question Id : 6364313188 Question Type : MCQ Option Shuffling : Yes Display Question Number : Yes Is Question Mandatory : No Option Orientation : Vertical Correct Marks : 1 Wrong Marks : 0

Given $L[f(t)] = \frac{(s+2)}{(s^2+1)}$, $L[g(t)] = \frac{(s^2+1)}{(s+3)(s+2)}$, and $h(t) = \int_0^t f(\tau)g(t-\tau) d\tau$.

Then, $L[h(t)]$ is

Options :

1. ✗
$$\frac{(s^2+1)}{(s-3)}$$

2. ✓
$$\frac{1}{(s+3)}$$

3. ✗
$$\frac{(s^2+1)}{(s+3)(s+2)} + \frac{(s+2)}{(s^2+1)}$$

4. ✘ $\frac{1}{(s-3)}$

Question Number : 69 Question Id : 6364313189 Question Type : MCQ Option Shuffling : Yes Display Question Number : Yes Is Question Mandatory : No Option Orientation : Vertical Correct Marks : 1 Wrong Marks : 0

The autocorrelation function of white noise is a

Options :

1. ✔ Delta function
2. ✘ Constant
3. ✘ Gaussian function
4. ✘ Exponential function

Question Number : 70 Question Id : 6364313190 Question Type : MCQ Option Shuffling : Yes Display Question Number : Yes Is Question Mandatory : No Option Orientation : Vertical Correct Marks : 1 Wrong Marks : 0

Consider a casual LTI system with frequency response $H(j\omega) = \frac{1}{(j\omega+3)}$ This system produces the output $y(t)$ to the input $x(t)$ as, $y(t) = e^{-3t} u(t) - e^{-4t} u(t)$. The input $x(t)$ is

Options :

1. ✘ $(2e^{-4t} - 3e^{-3t}) u(t)$

2. ✘ $(3e^{-4t} - 2e^{-3t}) u(t)$

3. ✘ $-e^{-4t} u(t)$

4. ✔ $e^{-4t} u(t)$

Question Number : 71 Question Id : 6364313191 Question Type : MCQ Option Shuffling : Yes Display Question Number : Yes Is Question Mandatory : No Option Orientation : Vertical Correct Marks : 1 Wrong Marks : 0

The energy of the signal $A\delta[n]$ is

Options :

1. ✔ A^2

2. ✘ $\frac{A^2}{2}$

3. ✘ $\frac{A^2}{4}$

4. ✘ 0

Question Number : 72 Question Id : 6364313192 Question Type : MCQ Option Shuffling : Yes Display Question Number : Yes Is

Question Mandatory : No Option Orientation : Vertical

Correct Marks : 1 Wrong Marks : 0

If $f(t) = -f(-t)$ and $f(t)$ satisfy the Dirichlet's condition, then $f(T)$ can be expandable in a Fourier series containing,

Options :

1. ✔ Only sine terms

2. ✘ Only cosine terms

3. ✘ Cosine and constant terms

4. ✘ Sine and constant terms

Question Number : 73 Question Id : 6364313193 Question Type : MCQ Option Shuffling : Yes Display Question Number : Yes Is

Question Mandatory : No Option Orientation : Vertical

Correct Marks : 1 Wrong Marks : 0

What is the refractive index of the cladding if the refractive index of the core and the relative refractive index are 1.558 and 0.015 respectively

Options :

1. ✘ 1.581
2. ✔ 1.534
3. ✘ 1.558
4. ✘ 1.543

Question Number : 74 Question Id : 6364313194 Question Type : MCQ Option Shuffling : Yes Display Question Number : Yes Is Question Mandatory : No Option Orientation : Vertical Correct Marks : 1 Wrong Marks : 0

The positive peaks of an AM voltage rise to a maximum value of 12V and drop to a minimum value of 4V. The modulation index assuming single tone modulation is

Options :

1. ✔ $1/2$
2. ✘ $1/4$
3. ✘ 4

4. ✘ 2

Question Number : 75 Question Id : 6364313195 Question Type : MCQ Option Shuffling : Yes Display Question Number : Yes Is Question Mandatory : No Option Orientation : Vertical Correct Marks : 1 Wrong Marks : 0

The modulating frequency in frequency modulation is increased from 10kHz to 20 kHz. The bandwidth is

Options :

1. ✔ Increases by 20 kHz

2. ✘ Increases tremendously

3. ✘ Doubled

4. ✘ Halved

Question Number : 76 Question Id : 6364313196 Question Type : MCQ Option Shuffling : Yes Display Question Number : Yes Is Question Mandatory : No Option Orientation : Vertical Correct Marks : 1 Wrong Marks : 0

If a discrete signal $x(n) = x(-n)$ then

Options :

1. ✘ Signal is odd and asymmetric

2. ✘ Signal is even and asymmetric
3. ✘ Signal is odd and symmetric
4. ✔ Signal is even and symmetric

Question Number : 77 Question Id : 6364313197 Question Type : MCQ Option Shuffling : Yes Display Question Number : Yes Is Question Mandatory : No Option Orientation : Vertical Correct Marks : 1 Wrong Marks : 0

A 60 kHz carrier is amplitude modulated by the speech band of 300 Hz to 3 kHz.

The range of upper side bands will be

Options :

1. ✘ 56.7 kHz to 56.3 kHz
2. ✘ 60 kHz to 59.7 kHz
3. ✔ 60.3 kHz to 63 kHz
4. ✘ 57.1 kHz to 59.7 kHz

Question Number : 78 Question Id : 6364313198 Question Type : MCQ Option Shuffling : Yes Display Question Number : Yes Is Question Mandatory : No Option Orientation : Vertical

Correct Marks : 1 Wrong Marks : 0

The carrier modulated by a digital bit stream had one of the possible phase of 270,180,90,0 degrees, then it is called as

Options :

1. ✘ BPSK
2. ✔ QPSK
3. ✘ QAM
4. ✘ MSK

Question Number : 79 Question Id : 6364313199 Question Type : MCQ Option Shuffling : Yes Display Question Number : Yes Is

Question Mandatory : No Option Orientation : Vertical

Correct Marks : 1 Wrong Marks : 0

A 1000KHz carrier is simultaneously modulated with 300Hz and 2 KHz audio sine waves. Which of the following frequencies will not be present in the output

Options :

1. ✘ 999.7 KHz
2. ✘ 998 KHz
3. ✔ 700 KHz

4. ✘ 1000.3 KHz

Question Number : 80 Question Id : 6364313200 Question Type : MCQ Option Shuffling : Yes Display Question Number : Yes Is Question Mandatory : No Option Orientation : Vertical Correct Marks : 1 Wrong Marks : 0

One of the main function of superheterodyne RF amplifier is to

Options :

1. ✘ Provide excellent adjacent channel selectivity
2. ✘ Increases the tuning range of the receiver
3. ✘ Provide better tracking
4. ✔ Improve image frequency rejection

Question Number : 81 Question Id : 6364313201 Question Type : MCQ Option Shuffling : Yes Display Question Number : Yes Is Question Mandatory : No Option Orientation : Vertical Correct Marks : 1 Wrong Marks : 0

An analog voltmeter uses external multiplier settings. With a multiplier setting of 20 k Ω it reads 440 V and with a multiplier setting of 80 k Ω it reads 352 V. For a multiplier setting of 40 k Ω the voltmeter reads

Options :

1. ✘ 371 V
2. ✘ 383 V
3. ✘ 394 V
4. ✔ 406 V

Question Number : 82 Question Id : 6364313202 Question Type : MCQ Option Shuffling : Yes Display Question Number : Yes Is

Question Mandatory : No Option Orientation : Vertical

Correct Marks : 1 Wrong Marks : 0

The slope and level detector circuit in a CRO has a delay of 100 ns. The start-stop sweep generator has a response time of 50 ns. In order to display correctly, a delay line of

Options :

1. ✔ 150 ns has to be inserted into the y-channel
2. ✘ 150 ns has to be inserted into the x-channel

3. ✘ 150 ns has to be inserted into both x and y channels
4. ✘ 100 ns has to be inserted into both x and y channels

Question Number : 83 Question Id : 6364313203 Question Type : MCQ Option Shuffling : Yes Display Question Number : Yes Is Question Mandatory : No Option Orientation : Vertical Correct Marks : 1 Wrong Marks : 0

Mass spectrometer separates ions on the basis of which of the following

Options :

1. ✘ Mass
2. ✘ Charge
3. ✘ Molecular weight
4. ✔ Mass to charge ratio

Question Number : 84 Question Id : 6364313204 Question Type : MCQ Option Shuffling : Yes Display Question Number : Yes Is Question Mandatory : No Option Orientation : Vertical Correct Marks : 1 Wrong Marks : 0

Wheatstone bridge is used to measure resistance in the range of



Options :

1. 1Ω to a few mega-ohms
2. ✘ $10k\Omega$ to a few mega-ohms
3. ✘ $100M\Omega$ to a few giga-ohms
4. ✘ 0.00001Ω to 10Ω

Question Number : 85 Question Id : 6364313205 Question Type : MCQ Option Shuffling : Yes Display Question Number : Yes Is

Question Mandatory : No Option Orientation : Vertical

Correct Marks : 1 Wrong Marks : 0

Three moving iron type voltmeters are connected as shown below. Voltmeter readings are V , V_1 and V_2 as indicated. The correct relation among the voltmeter readings is

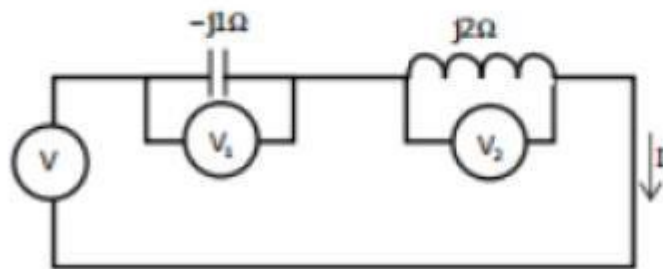

✔ Options :

1. ✘ $V = \frac{V_1}{\sqrt{2}} + \frac{V_2}{\sqrt{2}}$

2. $V = V_1 + V_2$

3. ✘ $V = V_1 V_2$

4. ✘ $V = V_2 - V_1$

Question Number : 86 Question Id : 6364313206 Question Type : MCQ Option Shuffling : Yes Display Question Number : Yes Is Question Mandatory : No Option Orientation : Vertical Correct Marks : 1 Wrong Marks : 0

A wattmeter is connected as shown in the figure. The wattmeter reads

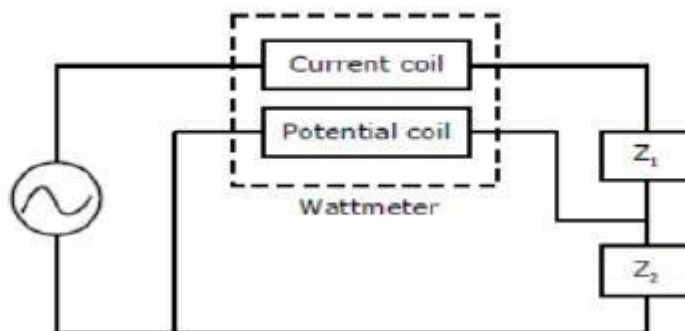

Options :

- ✔ 1. ✘ Zero always

2. ✘ Total power consumed by Z_1 and Z_2

3. ✘ Power consumed by Z_1

4. Power consumed by Z_2



Question Number : 87 Question Id : 6364313207 Question Type : MCQ Option Shuffling : Yes Display Question Number : Yes Is Question Mandatory : No Option Orientation : Vertical

Correct Marks : 1 Wrong Marks : 0

An ammeter has a current range of (0-5)A, and its internal resistance is 0.2Ω . In order to change the range to (0-25)A, we need to add a resistance of

Options :

1. ✘ $0.8\ \Omega$ in series with the meter.
2. ✘ $1.0\ \Omega$ in series with the meter.
3. ✘ $0.04\ \Omega$ in parallel with the meter.
4. ✔ $0.05\ \Omega$ in parallel with the meter.

Question Number : 88 Question Id : 6364313208 Question Type : MCQ Option Shuffling : Yes Display Question Number : Yes Is Question Mandatory : No Option Orientation : Vertical

Correct Marks : 1 Wrong Marks : 0

Katharometer works by measuring changes in _____

Options :

1. ✘ Electron flow

2. ✘ Absorbance
3. ✔ Thermal conductivity
4. ✘ Luminescence

Question Number : 89 Question Id : 6364313209 Question Type : MCQ Option Shuffling : Yes Display Question Number : Yes Is Question Mandatory : No Option Orientation : Vertical Correct Marks : 1 Wrong Marks : 0

Which of the following is an integrating instrument?

Options :

1. ✘ Galvanometer
2. ✘ Voltmeter
3. ✔ Watt hour meter
4. ✘ Ammeter

Question Number : 90 Question Id : 6364313210 Question Type : MCQ Option Shuffling : Yes Display Question Number : Yes Is Question Mandatory : No Option Orientation : Vertical Correct Marks : 1 Wrong Marks : 0

The bridge method commonly used for finding mutual inductance is

Options :

1. ✓ Heaviside Campbell bridge
2. ✗ Schering bridge
3. ✗ De Sauty bridge
4. ✗ Wien bridge

Question Number : 91 Question Id : 6364313211 Question Type : MCQ Option Shuffling : Yes Display Question Number : Yes Is Question Mandatory : No Option Orientation : Vertical Correct Marks : 1 Wrong Marks : 0

The chromatographic column type for liquid-solid mixture is _____ type

Options :

1. ✓ Gas absorption
2. ✗ Gas penetration
3. ✗ Liquid absorption
4. ✗ Solid penetration

Question Number : 92 Question Id : 6364313212 Question Type : MCQ Option Shuffling : Yes Display Question Number : Yes Is Question Mandatory : No Option Orientation : Vertical Correct Marks : 1 Wrong Marks : 0

The closed loop transfer function of the system is given by $\frac{10}{(s^2 + 6s + 10)}$. The damping ratio of the system is _____

Options :

1. ✘ 0.35
2. ✘ 0.65
3. ✔ 0.95
4. ✘ 1.25

Question Number : 93 Question Id : 6364313213 Question Type : MCQ Option Shuffling : Yes Display Question Number : Yes Is Question Mandatory : No Option Orientation : Vertical Correct Marks : 1 Wrong Marks : 0

A closed loop system has a unity feedback whose open loop transfer function is given by $\frac{1}{(s+0.2)(s+0.3)}$ and the proportional controller is cascaded with the system.

If the final steady state value of the closed loop system is 0.7 while the system is excited by unit step setpoint, then the proportional controller gain is _____

Options :

1. ✓ 0.140
2. ✗ 0.025
3. ✗ 3.270
4. ✗ 0.100

Question Number : 94 Question Id : 6364313214 Question Type : MCQ Option Shuffling : Yes Display Question Number : Yes Is Question Mandatory : No Option Orientation : Vertical Correct Marks : 1 Wrong Marks : 0

Consider the continuous time state space model of the system $\dot{x}(t) = Ax(t) + Bu(t)$ and $y(t) = Cx(t) + D$. The system exhibits unstable characteristics, when _____

Options :

1. ✘ All eigen values of B are negative
2. ✘ One or more eigen values of B are positive
3. ✔ One or more eigen values of A are positive
4. ✘ All eigen values of A are negative

Question Number : 95 Question Id : 6364313215 Question Type : MCQ Option Shuffling : Yes Display Question Number : Yes Is Question Mandatory : No Option Orientation : Vertical Correct Marks : 1 Wrong Marks : 0

State space model of the system is given by $\dot{x}(t) = \begin{bmatrix} 0 & 1 \\ -2 & -5 \end{bmatrix}x(t) + \begin{bmatrix} 1 \\ 1 \end{bmatrix}u(t)$ and $y(t) = [1 \quad 1]x(t) + [0]u(t)$. The transfer function of the system is _____

Options :

1. ✘ $\frac{s+6}{s^2+5s+2}$
2. ✘ $\frac{s+2}{s^2+5s+2}$

3. ✘
$$\frac{s+0.6}{0.5s^2+2.5s+1}$$

4. ✔
$$\frac{s+2}{0.5s^2+2.5s+1}$$

Question Number : 96 Question Id : 6364313216 Question Type : MCQ Option Shuffling : Yes Display Question Number : Yes Is Question Mandatory : No Option Orientation : Vertical Correct Marks : 1 Wrong Marks : 0

Compute $\frac{Y(s)}{U(s)}$ for the following signal flow graph.

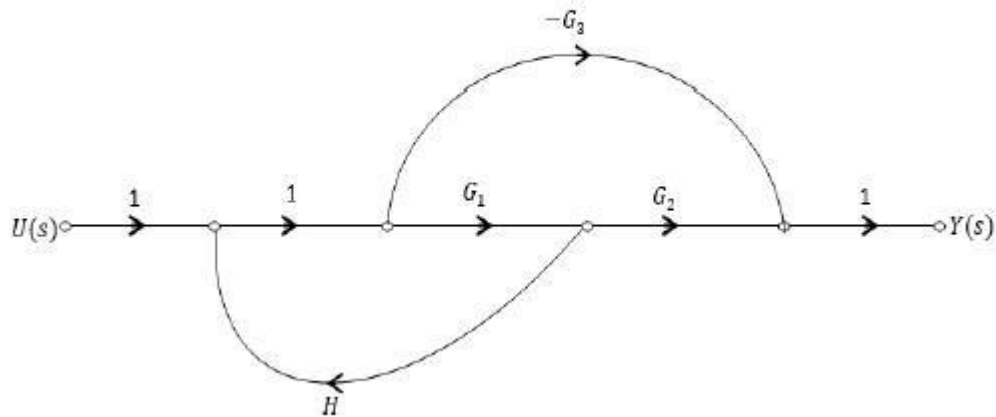

Options :

1. ✘
$$\frac{1-G_1H}{G_1G_2-G_2}$$

2. ✓ $\frac{G_1 G_2 - G_2}{1 - G_1 H}$

3. ✗ $\frac{G_1 G_2 - G_2}{1 + G_1 H}$

4. ✗ $\frac{1 + G_1 H}{G_1 G_2 - G_2}$

Question Number : 97 Question Id : 6364313217 Question Type : MCQ Option Shuffling : Yes Display Question Number : Yes Is Question Mandatory : No Option Orientation : Vertical Correct Marks : 1 Wrong Marks : 0

In a cascade controller design time constant of inner loop is T_1 and time constant of outer loop is T_2 . Then the relation between two time constants is

Options :

1. ✓ $T_1 < T_2$

2. ✗ $T_1 > T_2$

3. ✗ $T_1 = T_2$

4. ✗ $T_1 = 2T_2$

Question Number : 98 Question Id : 6364313218 Question Type : MCQ Option Shuffling : Yes Display Question Number : Yes Is Question Mandatory : No Option Orientation : Vertical Correct Marks : 1 Wrong Marks : 0

The characteristics equation of the closed loop system is represented as $s^5 + 4s^4 + 8s^3 + 8s^2 + 7s + 4 = 0$. The system has _____

Options :

1. ✘ One pole at origin and the system is marginally stable
2. ✘ All poles are at left half of the s – plane and the system is stable
3. ✔ A pair of complex conjugate poles are at imaginary axis and the system is marginally stable
4. ✘ The system is unstable

Question Number : 99 Question Id : 6364313219 Question Type : MCQ Option Shuffling : Yes Display Question Number : Yes Is Question Mandatory : No Option Orientation : Vertical Correct Marks : 1 Wrong Marks : 0

The polar plot of an open loop stable system is shown in the following figure. Then the system has _____

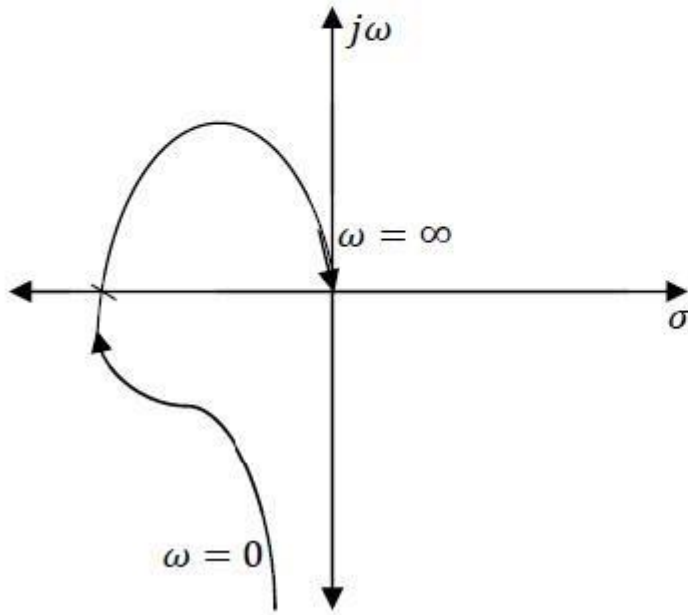

Options :

1. ✓ Third order with one pole at origin
2. ✗ Third order with no pole at origin
3. ✗ Second order with one pole at origin

4. ✘ Second order with no pole at origin

Question Number : 100 Question Id : 6364313220 Question Type : MCQ Option Shuffling : Yes Display Question Number : Yes Is Question Mandatory : No Option Orientation : Vertical Correct Marks : 1 Wrong Marks : 0

The system has a transfer function $G(s) = \frac{K(s^2 + 5s + 4)}{(s+2)(s+(4 \pm 4j))}$. The centroid of the root locus is _____

Options :

- 1. ✘ 1
- 2. ✘ -1
- 3. ✔ -5
- 4. ✘ 5

Question Number : 101 Question Id : 6364313221 Question Type : MCQ Option Shuffling : Yes Display Question Number : Yes Is Question Mandatory : No Option Orientation : Vertical Correct Marks : 1 Wrong Marks : 0

Needle electrodes which penetrate the skin are generally used for _____

Options :

1. ✘ Electro cardiogram
2. ✔ Electroencephalogram
3. ✘ Magnetic Resonance Imaging
4. ✘ X-Ray

Question Number : 102 Question Id : 6364313222 Question Type : MCQ Option Shuffling : Yes Display Question Number : Yes Is Question Mandatory : No Option Orientation : Vertical Correct Marks : 1 Wrong Marks : 0

A feedback system with the controller gain 2 has an open loop transfer function

$G(s) = \frac{K}{2s^2 + s}$. If the velocity error constant is 0.5, then the gain K is _____.

Options :

1. ✘ 2
2. ✔ 1
3. ✘ 0.5
4. ✘ 1.5

Question Number : 103 Question Id : 6364313223 Question Type : MCQ Option Shuffling : Yes Display Question Number : Yes Is Question Mandatory : No Option Orientation : Vertical Correct Marks : 1 Wrong Marks : 0

Consider the natural frequency and damping factor of the system are π rad/sec and 0.6 respectively. Then the peak time of the system is _____

Options :

1. ✓ 1.25 sec
2. ✗ 1.50 sec
3. ✗ 1.75 sec
4. ✗ 2.00 sec

Question Number : 104 Question Id : 6364313224 Question Type : MCQ Option Shuffling : Yes Display Question Number : Yes Is Question Mandatory : No Option Orientation : Vertical Correct Marks : 1 Wrong Marks : 0

Consider the solution to state equation $x(t) = \Phi(t) x(0)$. Where state transition

matrix $\Phi(t) = \begin{bmatrix} -e^{bt} & 0 \\ 0 & e^{-at} \end{bmatrix}$, then $\Phi^{-1}(t) =$ _____

Options :

1. ✗ $\begin{bmatrix} e^{bt} & 0 \\ 0 & e^{at} \end{bmatrix}$

2. ✘ $\begin{bmatrix} e^{-bt} & 0 \\ 0 & e^{at} \end{bmatrix}$

3. ✘ $\begin{bmatrix} -e^{-bt} & 0 \\ 0 & -e^{at} \end{bmatrix}$

4. ✔ $\begin{bmatrix} -e^{-bt} & 0 \\ 0 & e^{at} \end{bmatrix}$

Question Number : 105 Question Id : 6364313225 Question Type : MCQ Option Shuffling : Yes Display Question Number : Yes Is Question Mandatory : No Option Orientation : Vertical Correct Marks : 1 Wrong Marks : 0

The overall transfer function $\frac{C(s)}{R(s)}$ for the block diagram in the following figure.

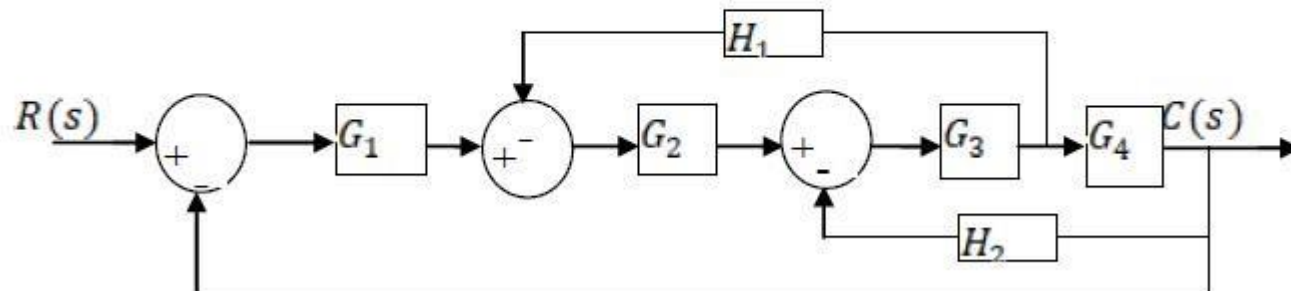

Options :

1. ✓
$$\frac{G_1 G_2 G_3 G_4}{1 + G_3 G_4 H_2 + G_2 G_3 H_1 + G_1 G_2 G_3 G_4}$$

2. ✗
$$\frac{G_1 G_2 G_3 G_4}{1 + G_3 G_4 H_2 + G_2 G_3 H_1 + G_1 G_2 G_3}$$

3. ✗
$$\frac{G_1 G_2 G_3 G_4}{1 + G_3 H_2 + G_2 G_3 H_1 + G_1 G_2 G_3 G_4}$$

4. ✗
$$\frac{G_1 G_2 G_3 G_4}{1 + G_3 H_2 + G_2 G_3 H_1 + G_1 G_2 G_3}$$

Question Number : 106 Question Id : 6364313226 Question Type : MCQ Option Shuffling : Yes Display Question Number : Yes Is

Question Mandatory : No Option Orientation : Vertical

Correct Marks : 1 Wrong Marks : 0

The plant model $G_p(s) = \frac{1.5}{0.5s+1}$ is cascaded with an integral controller $G_c(s) = 0.2 \frac{1}{s}$

and disturbance transfer function is $G_D(s) = \frac{0.1}{0.1s+1}$. Find the characteristic equation of

the closed loop system when feedback gain is 2.

Options :

1. ✘ $0.05s^3 + 0.6s^2 + s + 0.06 = 0$

2. ✔ $0.5s^2 + s + 0.6 = 0$

3. ✘ $0.5s^2 + s + 0.3 = 0$

4. ✘ $0.5s + 1.6 = 0$

Question Number : 107 Question Id : 6364313227 Question Type : MCQ Option Shuffling : Yes Display Question Number : Yes Is Question Mandatory : No Option Orientation : Vertical Correct Marks : 1 Wrong Marks : 0

Which of the following controller will improves the transient response

Options :

1. ✘ Proportional

2. ✘ Phase lag compensator

3. ✔ Phase lead compensator

4. ✘ Integrator

Question Number : 108 Question Id : 6364313228 Question Type : MCQ Option Shuffling : Yes Display Question Number : Yes Is Question Mandatory : No Option Orientation : Vertical

Correct Marks : 1 Wrong Marks : 0

A continuous time state space model of the flow process is given by

$$\dot{x}(t) = \begin{bmatrix} -3 & 2 \\ 4 & -5 \end{bmatrix} x(t) + \begin{bmatrix} 1 \\ 0 \end{bmatrix} u(t) \text{ and } y(t) = [0 \ 1]x(t). \text{ The flow process is}$$

Options :

1. ✘ Not completely controllable and not observable
2. ✔ Completely Controllable and completely observable
3. ✘ Only controllable completely
4. ✘ Only observable completely

Question Number : 109 Question Id : 6364313229 Question Type : MCQ Option Shuffling : Yes Display Question Number : Yes Is

Question Mandatory : No Option Orientation : Vertical

Correct Marks : 1 Wrong Marks : 0

The If $Y(z) = \frac{10}{(z-1)(z-0.2)}$ then $y(k)$ at $k = \infty$ is _____

Options :

1. ✘ 0
2. ✘ Infinity

3. ✓ 12.5

4. ✗ 1.25

Question Number : 110 Question Id : 6364313230 Question Type : MCQ Option Shuffling : Yes Display Question Number : Yes Is Question Mandatory : No Option Orientation : Vertical Correct Marks : 1 Wrong Marks : 0

A unity feedback system has a second order transfer function $G(s) = \frac{9}{s^2+6s+9}$.

Calculate the cross points of root locus in imaginary axis

Options :

1. ✗ $\pm 3 j\omega$

2. ✓ Never crosses imaginary axis

3. ✗ $\pm 2 j\omega$

4. ✗ $\pm 6 j\omega$

Question Number : 111 Question Id : 6364313231 Question Type : MCQ Option Shuffling : Yes Display Question Number : Yes Is Question Mandatory : No Option Orientation : Vertical Correct Marks : 1 Wrong Marks : 0

In a bode-plot of a unity feedback control system, the value of phase of $G(j\omega)$ at the gain cross over frequency is -115 degrees. The phase margin of the system is

Options :

1. ✘ 115 degrees
2. ✘ 295 degrees
3. ✘ Data is not sufficient
4. ✔ 65 degrees

Question Number : 112 Question Id : 6364313232 Question Type : MCQ Option Shuffling : Yes Display Question Number : Yes Is Question Mandatory : No Option Orientation : Vertical Correct Marks : 1 Wrong Marks : 0

Consider that the process equipment's are connected as shown in the following figure. The feed forward controller is to be designed for the system. To eliminate the complete impact of the disturbances in the process output, the controller transfer function $G_c(s)$ should be _____

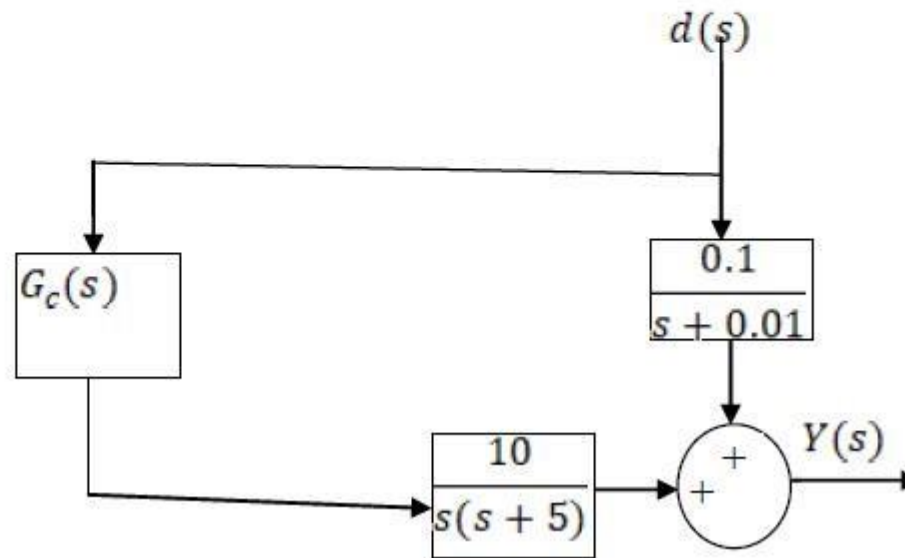

Options :

— $\frac{(0.01s^2 + 0.05s)}{(s+0.01)}$

1. ✓

$$\frac{(0.01s^2 + 0.05s)}{(s+0.01)}$$

2. ✘

$$\frac{(s+0.01)}{(0.01s^2 + 0.05s)}$$

3. ✘

$$\frac{(s+0.01)}{(0.01s^2 + 0.05s)}$$

4. ✘

Question Number : 113 Question Id : 6364313233 Question Type : MCQ Option Shuffling : Yes Display Question Number : Yes Is Question Mandatory : No Option Orientation : Vertical Correct Marks : 1 Wrong Marks : 0

Assume there is a 100 psi pressure drop across a control valve when the valve is wide open with a flow rate of 150 gpm of water through the valve. The specific gravity of water is one. The valve coefficient is _____

Options :

1. ✘ 1.5

2. ✔ 15

3. ✘ 0.667

4. ✘ 0.0667

Question Number : 114 Question Id : 6364313234 Question Type : MCQ Option Shuffling : Yes Display Question Number : Yes Is Question Mandatory : No Option Orientation : Vertical Correct Marks : 1 Wrong Marks : 0

In self-regulating process, the process is controlled _____ for nominal load variation

Options :

1. ✘ With the help of a controller

2. ✔ On its own without any controller

3. ✘ Using servo controller

4. ✘ Using regulatory controller

Question Number : 115 Question Id : 6364313235 Question Type : MCQ Option Shuffling : Yes Display Question Number : Yes Is Question Mandatory : No Option Orientation : Vertical Correct Marks : 1 Wrong Marks : 0

In ratio control scheme

Options :

1. ✘ Only one stream is measurable and both streams are controllable
2. ✘ Only one stream is measurable and the same stream is controllable
3. ✔ Two streams are measurable and only one stream is controllable
4. ✘ Two streams are measurable and both streams are controllable

Question Number : 116 Question Id : 6364313236 Question Type : MCQ Option Shuffling : Yes Display Question Number : Yes Is Question Mandatory : No Option Orientation : Vertical

Correct Marks : 1 Wrong Marks : 0

A system is represented by 6 equations and have 10 variables. Then degree of freedom of the system is

Options :

1. ✔ 4
2. ✘ - 4
3. ✘ 16
4. ✘ 60

Question Number : 117 Question Id : 6364313237 Question Type : MCQ Option Shuffling : Yes Display Question Number : Yes Is Question Mandatory : No Option Orientation : Vertical Correct Marks : 1 Wrong Marks : 0

_____ is most preferable for soft non-calcified tissue examination

Options :

1. ✘ CT Scan
2. ✔ Magnetic Resonance Imaging
3. ✘ Electrodermal response
4. ✘ Galvanic Skin Response

Question Number : 118 Question Id : 6364313238 Question Type : MCQ Option Shuffling : Yes Display Question Number : Yes Is Question Mandatory : No Option Orientation : Vertical Correct Marks : 1 Wrong Marks : 0

Settling time of the under damped system is _____

Options :

1. ✘ $2\zeta \omega_n$
2. ✘ $4\zeta \omega_n$

3. ✘ $\frac{\zeta\omega_n}{2}$

4. ✔ $4/\zeta\omega_n$

Question Number : 119 Question Id : 6364313239 Question Type : MCQ Option Shuffling : Yes Display Question Number : Yes Is Question Mandatory : No Option Orientation : Vertical Correct Marks : 1 Wrong Marks : 0

Which of the following non-linearity is caused by the servo motor?

Options :

1. ✘ Backlash

2. ✘ Static friction

3. ✘ Dynamic friction

4. ✔ Saturation

Question Number : 120 Question Id : 6364313240 Question Type : MCQ Option Shuffling : Yes Display Question Number : Yes Is Question Mandatory : No Option Orientation : Vertical Correct Marks : 1 Wrong Marks : 0

A four-phase stepper motor with 8 stator teeth and 6 rotor teeth, then the step angle of the motor is _____

Options :

1. ✓ 15°

2. ✗ 45°

3. ✗ 7.5°

4. ✗ 22.5°