

23/01/2025

Evening



Aakash

Medical | IIT-JEE | Foundations

Corporate Office : AESL, 3rd Floor, Incuspaze Campus-2, Plot-13, Sector-18, Udyog Vihar,
Gurugram, Haryana-122018

Memory Based Answers & Solutions

Time : 3 hrs.

for

M.M. : 300

JEE (Main)-2025 (Online) Phase-1

(Physics, Chemistry and Mathematics)

IMPORTANT INSTRUCTIONS:

- (1) The test is of **3 hours** duration.
- (2) This test paper consists of 75 questions. Each subject (PCM) has 25 questions. The maximum marks are 300.
- (3) This question paper contains **Three Parts**. **Part-A** is Physics, **Part-B** is Chemistry and **Part-C** is **Mathematics**. Each part has only two sections: **Section-A** and **Section-B**.
- (4) **Section - A** : Attempt all questions.
- (5) **Section - B** : Attempt all questions.
- (6) **Section - A (01 – 20)** contains 20 multiple choice questions which have **only one correct answer**. Each question carries **+4 marks** for correct answer and **-1 mark** for wrong answer.
- (7) **Section - B (21 – 25)** contains 5 **Numerical value** based questions. The answer to each question should be rounded off to the **nearest integer**. Each question carries **+4 marks** for correct answer and **-1 mark** for wrong answer.

Delivering Champions Consistently

JEE (Advanced) 2024

AIR	Name	Classroom
25	Rishi Shekher Shukla	2 Year Classroom
67	Krishna Sai Shishir	2 Year Classroom
78	Abhishek Jain	2 Year Classroom
93	Hardik Aggarwal	2 Year Classroom
95	Ujjwal Singh	2 Year Classroom
98	Rachit Aggarwal	2 Year Classroom

JEE (Main) 2024

AIR	Name	Classroom	State
1	Sarvvi Jais	2 Year Classroom	Karnataka
15	M Sai Divya Teja Reddy	2 Year Classroom	Telangana
19	Rishi Shekher Shukla	2 Year Classroom	Telangana

PHYSICS

SECTION - A

Multiple Choice Questions: This section contains 20 multiple choice questions. Each question has 4 choices (1), (2), (3) and (4), out of which **ONLY ONE** is correct.

Choose the correct answer:

1. Find total work done from A to E.

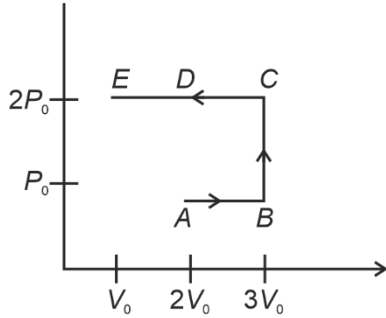

- (1) $-3 P_0 V_0$ (2) $3 P_0 V_0$
(3) $3 P_0 V_0$ (4) $5 P_0 V_0$

Answer (1)

Sol. Work done = Area under curve
 $= -4 P_0 V_0 + P_0 V_0$
 $= -3 P_0 V_0$

2. **Statement 1:** Graph of frequency f of X ray and atomic number Z of heavy nucleus is straight line, in X ray emission.

Statement 2: Graph of square root of frequency \sqrt{f} of X ray and atomic number Z of heavy nucleus is straight line, in X ray emission.

- (1) Statement 1 is correct and statement 2 is correct
 (2) Statement 1 is incorrect and statement 2 is correct
 (3) Statement 1 is correct and statement 2 is incorrect
 (4) Statement 1 is incorrect and statement 2 is incorrect

Answer (2)

Sol. Mosley law $\sqrt{f} = a(z - b)$

3. Two ideal diodes are connected in circuit as shown. Find current through battery.

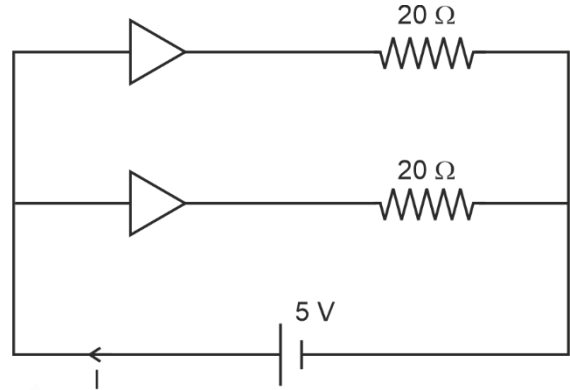

- (1) 0.3 A
 (2) 1 A
 (3) 0.5 A
 (4) 0.25 A

Answer (3)

Sol. Both diode are in forward bias.

$$I = \frac{5}{20} + \frac{5}{20}$$

$$I = 0.5 \text{ A}$$

4. In a series LCR circuit, inductance $L = 100 \text{ mH}$ and capacitance $C = 1 \text{ nF}$. The angular frequency of the source when current has maximum amplitude in the circuit is

- (1) $\frac{10^4}{2\pi} \text{ rad/s}$ (2) $\frac{10^5}{2\pi} \text{ rad/s}$
 (3) 10^5 rad/s (4) 10^6 rad/s

Answer (3)

Sol. The current is maximum at resonance,

$$\Rightarrow \omega = \frac{1}{\sqrt{LC}} = \frac{1}{\sqrt{(100 \times 10^{-3} \text{ H})(1 \times 10^{-9} \text{ F})}}$$

$$= 10^5 \text{ rad/s}$$

Delivering Champions Consistently

JEE (Advanced) 2024

- AIR 25 Rishi Shekher Shukla (2 Year Classroom)
- AIR 67 Krishna Sai Shishir (2 Year Classroom)
- AIR 78 Abhishek Jain (2 Year Classroom)
- AIR 93 Hardik Aggarwal (2 Year Classroom)
- AIR 95 Ujjwal Singh (2 Year Classroom)
- AIR 98 Rachit Aggarwal (2 Year Classroom)

JEE (Main) 2024

- Karnataka Topper: AIR 1 Sarvi Jais (2 Year Classroom)
- Telangana Topper: AIR 15 M Sai Divya Teja Reddy (2 Year Classroom)
- Telangana Topper: AIR 19 Rishi Shekher Shukla (2 Year Classroom)

5. Two charges +7 C and -4 C are located at (-7, 0, 0) and (7, 0, 0), find electrostatic potential energy of the system. $\left(k = \frac{1}{4\pi\epsilon_0} = 9 \times 10^9 \text{ SI units} \right)$

- (1) $-6 \times 10^9 \text{ J}$ (2) $-18 \times 10^9 \text{ J}$
 (3) $18 \times 10^9 \text{ J}$ (4) $6 \times 10^9 \text{ J}$

Answer (2)

Sol. $E = \frac{Kq_1q_2}{r}$
 $= \frac{-9 \times 10^9 \times 7 \times 4}{14}$
 $= -18 \times 10^9 \text{ J}$

6. A satellite is nine times closer to earth compared to moon. Time period of moon is 27 days then period of satellite is

- (1) 3 days
 (2) 9 days
 (3) 1 day
 (4) $3\sqrt{3}$ days

Answer (3)

Sol. $\frac{T_m^2}{T_s^2} = \left(\frac{r_m}{r_s}\right)^3 = 9^3$
 $\Rightarrow T_s = \frac{T_m}{9^{3/2}} = 1 \text{ day}$

7. A concave mirror of focal length f dipped into a fluid of refractive index μ . The new focal length mirror is

- (1) μf (2) f
 (3) $\frac{f}{\mu - 1}$ (4) $\frac{f}{\mu}$

Answer (2)

Sol. Focal length of spherical mirror does not depend on medium in which it placed.

8. In an electromagnetic wave of frequency 20 MHz, value of electric field is 9.3 V/m, then magnitude of magnetic field at that instant is

- (1) 3.1×10^8
 (2) 27.9×10^8
 (3) 3.1×10^{-8}
 (4) 18.6×10^{-6}

Answer (3)

Sol. $E = CB$
 $\Rightarrow B = \frac{9.3}{3 \times 10^8} = 3.1 \times 10^{-8} \text{ T}$

9. Match the correct dimensions

(a)	Magnetic field	(i)	ML^2
(b)	Permittivity of free space	(ii)	$M^{-1}L^{-3}T^4A^2$
(c)	Moment of inertia	(iii)	$MT^{-2}A^{-1}$
(d)	Velocity	(iv)	LT^{-1}

- (1) (a) \rightarrow (iii), (b) \rightarrow (ii), (c) \rightarrow (i), (d) \rightarrow (iii)
 (2) (a) \rightarrow (iii), (b) \rightarrow (iv), (c) \rightarrow (iv), (d) \rightarrow (iv)
 (3) (a) \rightarrow (iii), (b) \rightarrow (ii), (c) \rightarrow (i), (d) \rightarrow (iv)
 (4) (a) \rightarrow (i), (b) \rightarrow (ii), (c) \rightarrow (iii), (d) \rightarrow (iv)

Answer (3)

Sol. $qvB = F$
 $B = \frac{MLT^{-2}}{A}$
 $MT^{-2}A^{-1}$
 $\frac{q}{\epsilon_0} = EA$
 $\frac{1}{\epsilon_0} = \frac{MLT^{-2}}{AT} \frac{L^2}{AT}$
 $\epsilon_0 = \frac{A^2T^2}{ML^3T^{-2}}$

Delivering Champions Consistently

JEE (Advanced) 2024

- AIR 25: Rishi Shekher Shukla (2 Year Classroom)
- AIR 67: Krishna Sai Shishir (2 Year Classroom)
- AIR 78: Abhishek Jain (2 Year Classroom)
- AIR 93: Hardik Aggarwal (2 Year Classroom)
- AIR 95: Ujjwal Singh (2 Year Classroom)
- AIR 98: Rachit Aggarwal (2 Year Classroom)

JEE (Main) 2024

- Karnataka Topper: AIR 1: Sarvi Jais (2 Year Classroom)
- Telangana Topper: AIR 15: M Sai Divya Teja Reddy (2 Year Classroom)
- Telangana Topper: AIR 19: Rishi Shekher Shukla (2 Year Classroom)

10. The temperature of a body of mass m and specific heat capacity s is raised slowly from T_1 to T_2 . The change in entropy of the system is

(1) $ms \ln\left(\frac{T_2}{T_1}\right)$

(2) ms

(3) $ms \ln\left(\frac{T_1}{T_2}\right)$

(4) Zero

Answer (1)

Sol. $d(\text{Entropy})_{\text{sys}} = \frac{dQ}{T}$

$$(\Delta \text{Entropy})_{\text{sys}} = \int_{T_1}^{T_2} \frac{dQ}{T}$$

$$= ms \int_{T_1}^{T_2} \frac{dT}{T}$$

$$= ms \ln \frac{T_2}{T_1}$$

11. A moving coil galvanometer with coil resistance $G = 30 \Omega$, shows full scale deflection when the current through it is 20 mA. The galvanometer is converted to an ammeter of range 3 A by using a shunt resistance S , then resistance S is

(1) 0.2Ω

(2) 2Ω

(3) 0.8Ω

(4) 1.2Ω

Answer (1)

Sol. $i_g G = IS$

$$S = \frac{i_g G}{I}$$

$$= \frac{(20 \times 10^{-3} \text{ A})(30 \Omega)}{(3 \text{ A})}$$

$$= \frac{1}{5} \Omega$$

12. Torque on a uniform disk of mass 2 kg, radius 1 m is given as $\tau(t) = 5t^2 - 8t$. If the disk was initially at rest, find power by torque at $t = 1$ s.

(1) 5 W

(2) 3 W

(3) 7 W

(4) 9 W

Answer (3)

Sol. $\rho = \vec{\tau} \cdot \vec{\omega}$

$$\tau = I\alpha$$

$$I = \frac{MR^2}{2} = 1$$

$$\alpha = 5t^2 - 8t$$

$$\omega = \frac{5}{3}t^3 - 4t^2$$

$$\text{At } t = 1, \omega = \frac{5}{3} - 4 = -\frac{7}{3}$$

$$\tau(1) = 5 - 8 = -3$$

$$\rho = \vec{\tau} \cdot \vec{\omega} = 7 \text{ W}$$

Delivering Champions Consistently

JEE (Advanced) 2024

AIR 25 Rishi Shekher Shukla 2 Year Classroom	AIR 67 Krishna Sai Shishir 2 Year Classroom	AIR 78 Abhishek Jain 2 Year Classroom	AIR 93 Hardik Aggarwal 2 Year Classroom	AIR 95 Ujjwal Singh 2 Year Classroom	AIR 98 Rishabh Aggarwal 2 Year Classroom
---	--	--	--	---	---

JEE (Main) 2024

Karnataka Topper AIR 1 Sarvi Jais 2 Year Classroom	Telangana Topper AIR 15 M Sai Divya Tuja Reddy 2 Year Classroom	Telangana Topper AIR 19 Rishi Shekher Shukla 2 Year Classroom
---	--	--

13. During charging of capacitor of $2.5 \mu\text{F}$ in DC circuit, the displacement current is found to be 0.25 mA then

find rate of change of voltage V w.r.t. time $\frac{dV}{dt}$.

- (1) 1 V/s
- (2) 10 V/s
- (3) 100 V/s
- (4) 0.1 V/s

Answer (3)

Sol. $V = \frac{q}{C}$

$$\frac{dV}{dt} = \frac{i}{C} = \frac{0.25 \times 10^{-3}}{2.5 \times 10^{-6}}$$

$$\frac{1000}{10}$$

14. In a photoelectric experiment, the stopping potential of 2 V , the work function of metal is 2.14 eV . Find the wavelength of incident light (given $hc = 1242 \text{ eV-nm}$)

- (1) 200 nm
- (2) 300 nm
- (3) 600 nm
- (4) 400 nm

Answer (2)

Sol. $E = 2 + 2.14 = 4.14 \text{ eV}$

$$E = \frac{hc}{\lambda}$$

$$\therefore \lambda = \frac{1242}{4.14} = 300 \text{ nm}$$

15. The equation of wave travelling in a medium is given by $y(x, t) = 4.0 \sin(20 \times 10^{-3}x + 600t)$ mm. The velocity of wave is $n \times 10^4 \text{ m/s}$. Find n .

- (1) 7
- (2) 5
- (3) 4
- (4) 3

Answer (4)

Sol. Velocity of wave = $\frac{\text{Coefficient of } t}{\text{Coefficient of } x}$

$$= \frac{600}{20 \times 10^{-3}}$$

$$= 3 \times 10^4 \text{ m/s}$$

$$n = 3$$

- 16.
- 17.
- 18.
- 19.
- 20.

SECTION - B

Numerical Value Type Questions: This section contains 5 Numerical based questions. The answer to each question should be rounded-off to the nearest integer.

21. Find charge on the capacitor (in μF) at steady state.

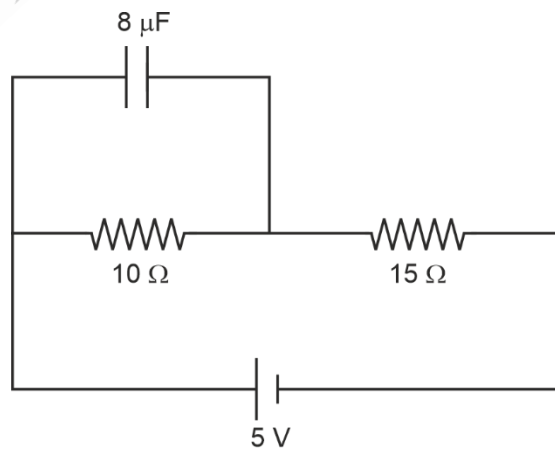

Answer (16)

Delivering Champions Consistently

JEE (Advanced) 2024

AIR 25 Rishi Shekher Shukla 2 Year Classroom	AIR 67 Krishna Sai Shishir 2 Year Classroom	AIR 78 Abhishek Jain 2 Year Classroom	AIR 93 Hardik Aggarwal 2 Year Classroom	AIR 95 Ujjwal Singh 2 Year Classroom	AIR 98 Rachit Aggarwal 2 Year Classroom
---	--	--	--	---	--

JEE (Main) 2024

Karnataka Topper AIR 1 Sarvi Jain 2 Year Classroom	Telangana Topper AIR 15 M Sai Divya Teja Reddy 2 Year Classroom	Telangana Topper AIR 19 Rishi Shekher Shukla 2 Year Classroom
---	--	--

Sol. $i = \frac{5}{25} = \frac{1}{5} \text{ A}$

$$V = 10 \times \frac{1}{5} = 2 \text{ V}$$

$$Q = CV = 8 \times 2 \mu\text{F} = 16 \mu\text{F}$$

22. A particle of mass m is projected at angle 60° with horizontal. If initial kinetic energy is KE_0 and kinetic energy at maximum height is $\frac{KE_0}{x}$, find value of x .

Answer (4)

Sol. $KE_0 = \frac{1}{2} mV^2$

$$KE = \frac{1}{2} m(V \cos 60^\circ)^2$$

$$= \frac{1}{2} m \frac{V^2}{4}$$

$$x = 4$$

23. The energy in a system varies with position and time as $E(x, t) = x^3 e^{-\beta t}$, where $\beta = 0.3 \text{ sec}^{-1}$. Given that the percentage error in $x = 1.2\%$ and that the % error in $t = 1.6\%$, find the maximum % error in E at $t = 5 \text{ sec}$.

Answer (6)

Sol. $E = x^3 e^{-\beta t}$

$$\ln E = 3 \ln x - \beta t$$

$$\frac{1}{E} dE = \frac{3}{x} dx - \beta dt$$

$$\left(\frac{dE}{E} \times 100\right) = 3\left(\frac{dx}{x} \times 100\right) + 100\beta dt$$

$$\% \text{ error in } E = 3(1.2\%) + (100)(0.3)\left(\frac{1.6}{100} \times 5\right)\%$$

$$\% \text{ error in } E = 6\%$$

24. For a prism, the minimum deviation is equal to the angle of prism. If the refractive index is $\sqrt{3}$, find the minimum deviation (in degrees)

Answer (60)

Sol. $\mu = \frac{\sin\left(\frac{A+\delta}{2}\right)}{\sin\left(\frac{A}{2}\right)}$

$$\mu = 2 \cos\left(\frac{A}{2}\right)$$

$$\frac{A}{2} = 30^\circ$$

$$A = 60^\circ$$

$$\therefore \delta = 60^\circ$$

25. A satellite of mass m is moving in circular orbit at a height R from surface of Earth (mass M , radius R). If the angular momentum of the satellite is $m\sqrt{NGMR}$, find N .

Answer (2)

Sol. $L = mvr$

$$= m\sqrt{\frac{GM}{2R}} \cdot 2R$$

$$= m\sqrt{2GMR}$$

Delivering Champions Consistently

JEE (Advanced) 2024

AIR 25 Rishi Shekher Shukla 2 Year Classroom	AIR 67 Krishna Sai Shishir 2 Year Classroom	AIR 78 Abhishek Jain 2 Year Classroom	AIR 93 Hardik Aggarwal 2 Year Classroom	AIR 95 Ujjwal Singh 2 Year Classroom	AIR 98 Rachit Aggarwal 2 Year Classroom
---	--	--	--	---	--

JEE (Main) 2024

100 PERCENTILE RANK AIR 1 Sarvi Jais 2 Year Classroom	100 PERCENTILE RANK AIR 15 M Sai Divya Teja Reddy 2 Year Classroom	100 PERCENTILE RANK AIR 19 Rishi Shekher Shukla 2 Year Classroom
--	---	---

Karnataka Topper **Telangana Topper** **Telangana Topper**

CHEMISTRY

SECTION - A

Multiple Choice Questions: This section contains 20 multiple choice questions. Each question has 4 choices (1), (2), (3) and (4), out of which **ONLY ONE** is correct.

Choose the correct answer :

1. The correct order of melting points of Group-14 elements is
- (1) $C > Si > Ge > Sn > Pb$
 - (2) $Si > C > Ge > Sn > Pb$
 - (3) $Ge > Sn > C > Si > Pb$
 - (4) $C > Si > Ge > Pb > Sn$

Answer (4)

Sol. Melting Points (in K)

C	Si	Ge	Sn	Pb
4373	1693	1218	505	600

Correct order will be



2. α -helix protein and β -pleated sheets protein belong to which one of the following types of protein?
- (1) Primary
 - (2) Secondary
 - (3) Tertiary
 - (4) Quarternary

Answer (2)

Sol. α -helix and β -pleated sheet structure belong to secondary protein or 2° protein.

3. What will be effect on pH of water when it is heated?
- (1) Increase
 - (2) Decrease
 - (3) Remains same
 - (4) pH first increases then decreases

Answer (2)

Sol. As water is heated degree of ionisation increases $[H^+]$ ion concentration increases pH decreases.

4. Match the following List I with List II.

List-I (Alloys)		List-II (Metals)	
A.	Bronze	(i)	Fe, Cr, and Ni
B	Stainless steel	(ii)	Cu and Sn
C	UK Gold Coin	(iii)	Cu and Zn
D	Brass	(iv)	Au, Ag, Cu, Zn and Ni

- (1) A-(ii), B-(i), C-(iv), D-(iii)
- (2) A-(iii), B-(iv), C-(i), D-(ii)
- (3) A-(iv), B-(iii), C-(ii), D-(i)
- (4) A-(i), B-(ii), C-(iii), D-(iv)

Answer (1)

Sol. ▶ Bronze is Made up of copper and Tin

▶ Stainless steel is made up of Fe, Cr and Ni

▶ UK Gold coin is made up of – Au (91%), Ag, Cu, Zn and Ni.

▶ Brass is made up of Copper and Zinc.

5. Which one of the following plots represents zero order reaction?

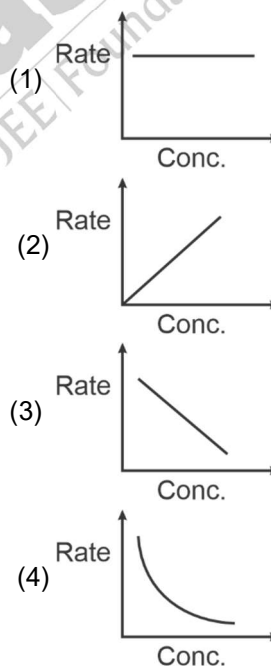



Delivering Champions Consistently



Aakash
Medical IIT-JEE Foundations

JEE (Advanced) 2024



AIR 25

Rishi Shekher Shukla
2 Year Classroom



AIR 67

Krishna Sai Shihir
2 Year Classroom



AIR 78

Abhishek Jain
2 Year Classroom



AIR 93

Hardik Aggarwal
2 Year Classroom



AIR 95

Ujjwal Singh
2 Year Classroom



AIR 98

Rishit Aggarwal
2 Year Classroom

JEE (Main) 2024



AIR 1

Sarvi Jain
2 Year Classroom



AIR 15

M Sai Divya Teja Reddy
2 Year Classroom



AIR 19

Rishi Shekher Shukla
2 Year Classroom

Answer (1)

Sol. The rate of a zero order reaction remains constant throughout the reaction.

$$\text{Rate} = k [\text{Reactant}]^0$$

Plot of rate vs conc. of reactant is linear parallel to x-axis.

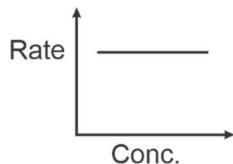

6. By using relation

$$\Delta G = \Delta H - T\Delta S$$

Which of the following relation is incorrect for spontaneous reaction at a given temperature?

- (1) $\Delta H > 0, \Delta S > 0$ (2) $\Delta H > 0, \Delta S < 0$
 (3) $\Delta H < 0, \Delta S > 0$ (4) $\Delta H < 0, \Delta S < 0$

Answer (2)

Sol. If $\Delta H > 0, \Delta S > 0$, then process is spontaneous at high temperature

If $\Delta H > 0, \Delta S < 0$, process is always non spontaneous

If $\Delta H < 0$ and $\Delta S > 0$, then process is always spontaneous

If $\Delta H < 0$ and $\Delta S < 0$, then process is spontaneous at low temperature.

7. **Statement-I** : For a particular shell, maximum number of orbitals is n^2 .

Statement-II : For a subshell, possible orientations lies between $-l$ to $+l$ including zero.

- (1) Statement-I and Statement -II both are correct
 (2) Statement-I and Statement-II both are incorrect
 (3) Statement-I is correct, Statement-II is incorrect
 (4) Statement-I is incorrect, Statement-II is correct

Answer (1)

Sol. If shell number is 2, then number of orbitals = $2^2 = 4$

$$2s \rightarrow \square; 2p \rightarrow \square\square\square = 4$$

If $l = 2$, then value lies between $-2, -1, 0, +1, +2$.

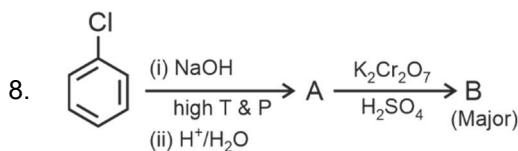

Predict A and B?

- (1) (2)
 (3) (4) None of these

Answer (3)

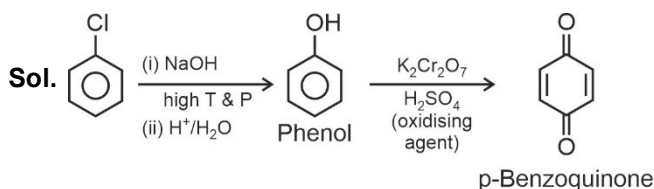

9. Which of the following complex has d^4 configuration?

- (1) $[\text{Fe}(\text{CN})_6]^{3-}$ (2) $[\text{MnF}_6]^{3-}$
 (3) $[\text{Co}(\text{CN})_6]^{3-}$ (4) $[\text{CoCl}_4]^{2-}$

Answer (2)

Sol. $[\text{Fe}(\text{CN})_6]^{3-} \Rightarrow \text{Fe}^{3+} \Rightarrow 3d^5$ configuration

$[\text{MnF}_6]^{3-} \Rightarrow \text{Mn}^{3+} \Rightarrow 3d^4$ configuration

$[\text{Co}(\text{CN})_6]^{3-} \Rightarrow \text{Co}^{3+} \Rightarrow 3d^6$ configuration

$[\text{CoCl}_4]^{2-} \Rightarrow \text{Co}^{2+} \Rightarrow 3d^7$ configuration

10. The total number of isomers possible (aldehyde & ketones) for $\text{C}_4\text{H}_8\text{O}$ are

- (1) 3 (2) 4
 (3) 5 (4) 6

Answer (1)

Sol.

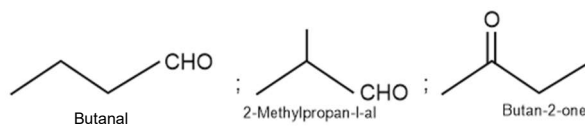

Delivering Champions Consistently

JEE (Advanced) 2024

AIR 25 **Rishi Shekher Shukla** (2 Year Classroom)
 AIR 67 **Krishna Sai Shihir** (2 Year Classroom)
 AIR 78 **Abhishek Jain** (2 Year Classroom)
 AIR 93 **Hardik Aggarwal** (2 Year Classroom)
 AIR 95 **Ujjwal Singh** (2 Year Classroom)
 AIR 98 **Rishit Aggarwal** (2 Year Classroom)

JEE (Main) 2024

Karnataka Topper: AIR 1 **Sarvi Jain** (2 Year Classroom) (100 Percentile)
 Telangana Topper: AIR 15 **M Sai Divya Teja Reddy** (2 Year Classroom) (100 Percentile)
 Telangana Topper: AIR 19 **Rishi Shekher Shukla** (2 Year Classroom) (100 Percentile)

11. Consider the following reaction

$X_2Y(s) \rightleftharpoons X_2(g) + \frac{1}{2}Y_2(g)$. If α is the degree of dissociation. Calculate K_P in terms of P (total pressure)

(1) $K_P = \frac{2P^{3/2}}{3^{3/2}}$ (2) $K_P = \frac{2P^{3/2}}{3}$

(3) $K_P = \sqrt{\frac{2P}{3}}$ (4) $K_P = \frac{\sqrt{2P}}{3}$

Answer (1)

Sol. $X_2Y(s) \rightleftharpoons X_2(g) + \frac{1}{2}Y_2(g)$

at eq. $P' \quad \frac{P'}{2}$

$P_T = \frac{3P'}{2} \Rightarrow P' = \left(\frac{2P_T}{3}\right)$

$K_P = (P_{X_2})(P_{Y_2})^{1/2}$

$K_P = P' \left(\frac{P'}{2}\right)^{1/2} = \frac{(P')^{3/2}}{\sqrt{2}} = \frac{\left(\frac{2P}{3}\right)^{3/2}}{\sqrt{2}} = \frac{2P^{3/2}}{3^{3/2}}$

12. An ideal gas undergoes following process from $A \rightarrow B \rightarrow C \rightarrow D \rightarrow E$. Find work done.

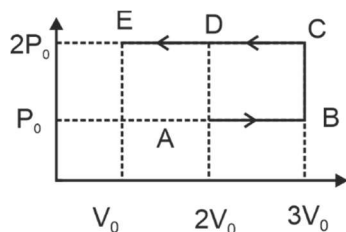

- (1) $-3P_0V_0$
- (2) $2P_0V_0$
- (3) $3P_0V_0$
- (4) $\frac{3P_0V_0}{2}$

Answer (3)

Sol. $|W| = \text{Area under the curve}$

$= 2P_0 \times [3V_0 - V_0] - P_0 \times [3V_0 - 2V_0]$
 $= 3P_0V_0$

Net work is done on the system.

13. When a non-volatile solute (A) is added to a volatile solvent, the vapour pressure of solvent decreases by 10 mm Hg. Mole fraction of solute in solution is 0.2. If another non-volatile solute (B) is further added to the same solution and vapour pressure of solution decreases by 20 mm Hg, calculate mole fraction of 2nd solute in the final solution.

- (1) 0.3
- (2) 0.4
- (3) 0.5
- (4) 0.6

Answer (3)

Sol. For solute (A),

$X_A = 0.2$

$\Delta P = 10 \text{ mm Hg}$

Let P_{solvent}^0 be vapour pressure of pure solvent

$\frac{\Delta P}{P_{\text{solvent}}^0} = X_A$

$P_{\text{solvent}}^0 = \frac{10}{0.2} = 50 \text{ mm Hg}$

For solute (B),

Let number of moles of solvent be 0.8 and n_B be the number of moles of (B) added, then

$X_B = \frac{n_B}{0.2 + 0.8 + n_B} = \frac{n_B}{1 + n_B}$

$\Delta P' = 10 + 20 = 30 \text{ mm Hg}$

$$\frac{\Delta P'}{P_{\text{solvent}}^{\circ}} = \frac{0.2 + n_B}{1 + n_B}$$

$$\frac{30}{50} = \frac{0.2 + n_B}{1 + n_B}$$

$$\Rightarrow n_B = 1$$

$$X_B = \frac{1}{1+1} = 0.5$$

14. Consider the following E° values of given half cell

$$E_{\text{Ag}^+/\text{Ag}}^{\circ} = 0.8 \text{ V}, E_{\text{Zn}^{2+}/\text{Zn}}^{\circ} = -0.76 \text{ V}$$

$$E_{\text{Cu}^{2+}/\text{Cu}}^{\circ} = 0.34 \text{ V}, E_{\text{Mg}^{2+}/\text{Mg}}^{\circ} = -2.36 \text{ V}$$

Then which of the following will have the most negative value of ΔG° ?

- (1) $\text{Zn}|\text{Zn}^{2+}||\text{Cu}^{2+}|\text{Cu}$
- (2) $\text{Mg}|\text{Mg}^{2+}||\text{Ag}^+|\text{Ag}$
- (3) $\text{Mg}|\text{Mg}^{2+}||\text{Zn}^{2+}|\text{Zn}$
- (4) $\text{Cu}|\text{Cu}^{2+}||\text{Ag}^+|\text{Ag}$

Answer (2)

Sol. The cell which has most positive value of E_{Cell}° will have most negative value of ΔG° .

$$E_{\text{cell}}^{\circ} = E_{\text{Ag}^+/\text{Ag}}^{\circ} - E_{\text{Mg}^{2+}/\text{Mg}}^{\circ} = 0.8 - (-2.36) = 3.16 \text{ V}$$

$$\Delta G^{\circ} = -nFE_{\text{Cell}}^{\circ}$$

15. Match the following

	Reactant		Product
(A)		(i)	
(B)		(ii)	

(C)		(iii)	
(D)		(iv)	

Give correct product of oxidative ozonolysis ($\text{O}_3/\text{H}_2\text{O}$)

- (1) A-ii, B-i, C-iii, D-iv
- (2) A-i, B-ii, C-iii, D-iv
- (3) A-i, B-ii, C-iv, D-iii
- (4) A-i, B-iv, C-ii, D-iii

Answer (2)

Sol.

16. Arrange the following compounds in the decreasing order of rate of hydrolysis

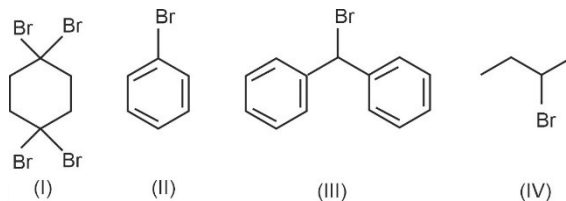

- (1) (I) > (II) > (III) > (IV)
- (2) (III) > (IV) > (I) > (II)
- (3) (IV) > (III) > (I) > (II)
- (4) (III) > (II) > (IV) > (I)

Answer (2)

Sol. Rate of hydrolysis of the given compounds will be decided on the basis of stability of carbocation intermediate. Higher the stability of carbocation, higher will be the rate of hydrolysis of the parent compound. Stability order of carbocations obtained from the given compounds.

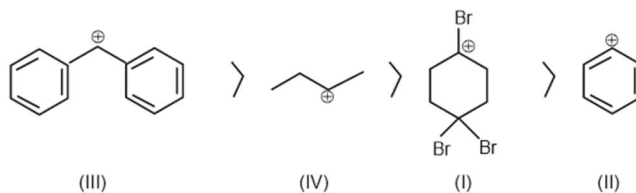

Delivering Champions Consistently

JEE (Advanced) 2024						JEE (Main) 2024		
 AIR 25 Rishi Shekher Shukla 2 Year Classroom	 AIR 67 Krishna Sai Shishir 2 Year Classroom	 AIR 78 Abhishek Jain 2 Year Classroom	 AIR 93 Harshil Aggarwal 2 Year Classroom	 AIR 95 Ujjwal Singh 2 Year Classroom	 AIR 98 Rishit Aggarwal 2 Year Classroom	 Karnataka Topper 100 PERCENTILE Sanyal Jain 2 Year Classroom	 Telangana Topper 100 PERCENTILE M Sai Divya Teja Reddy 2 Year Classroom	 Telangana Topper 100 PERCENTILE Rishi Shekher Shukla 2 Year Classroom

17. 0.01 mole of an organic compound (Hydrocarbon) gives 1.76 gm CO₂ and 0.9 gm H₂O on complete combustion. Find out chemical formula of compound.

- (1) C₃H₈
- (2) C₄H₁₀
- (3) C₅H₁₂
- (4) C₆H₁₄

Answer (2)

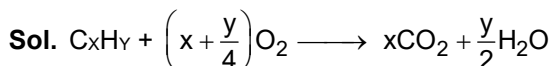

$$x = \frac{0.04}{0.01} = 4$$

$$\frac{y}{2} = 5$$

$$y = 10$$

Formula is C₄H₁₀

18.

19.

20.

SECTION - B

Numerical Value Type Questions: This section contains 5 Numerical based questions. The answer to each question should be rounded-off to the nearest integer.

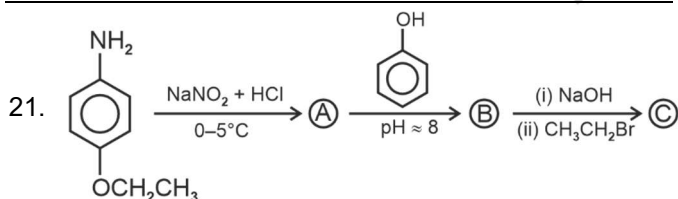

Number of sp³ hybridised carbon atoms in C is :

Answer (4)

Sol.

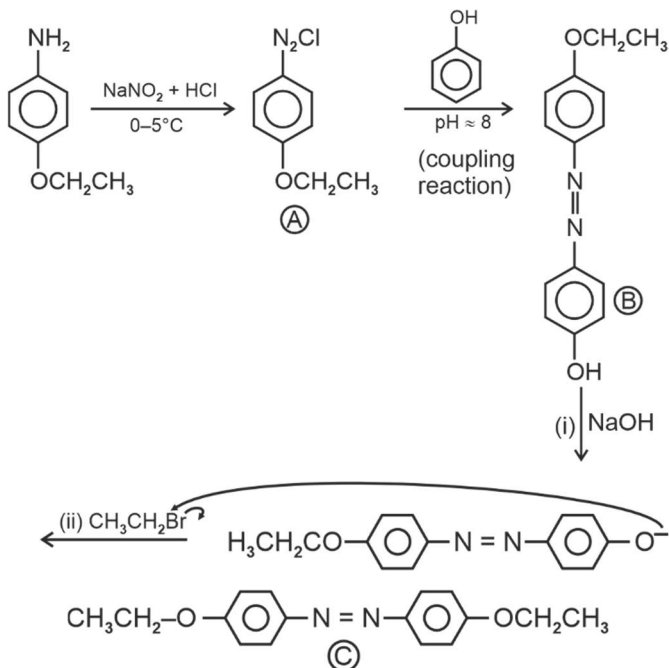

Total 4 sp³ hybridised carbon atoms are present in C

22. A compound X consumes two moles of H₂ and when 'X' heated with KMnO₄/H⁺ gives

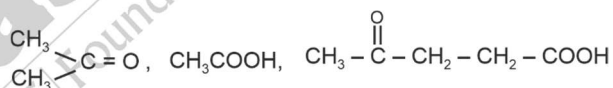

Number of σ bonds in X are _____.

Answer (27)

Sol. Compound X has 27 σ-bonds

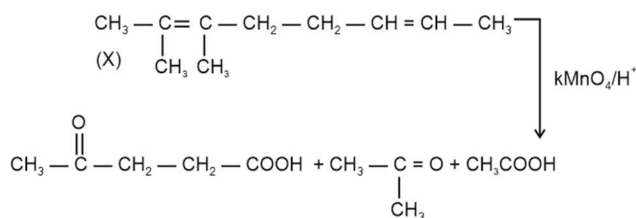

23.

24.

25.

Delivering Champions Consistently

JEE (Advanced) 2024

AIR 25 Rishi Shekher Shukla 2 Year Classroom	AIR 67 Krishna Sai Shihir 2 Year Classroom	AIR 78 Abhishek Jain 2 Year Classroom	AIR 93 Harshik Aggarwal 2 Year Classroom	AIR 95 Ujjwal Singh 2 Year Classroom	AIR 98 Rishit Aggarwal 2 Year Classroom
--	--	---	--	--	---

JEE (Main) 2024

Karnataka Topper AIR 1 Sarvi Jain 2 Year Classroom	Telangana Topper AIR 15 M Sai Divya Teja Reddy 2 Year Classroom	Telangana Topper AIR 19 Rishi Shekher Shukla 2 Year Classroom
--	---	---

$$(\sin^4 x + \cos^4 x) = (\sin^2 x + \cos^2 x)^2 - 2\sin^2 x \cos^2 x$$

$$= \left(1 - \frac{\sin^2 2x}{2}\right) = \frac{2 - \sin^2 x}{2}$$

$$= \frac{1 - \cos^2 2x}{2}$$

$$2I = \frac{\pi}{4} \int_0^{\frac{\pi}{2}} \frac{\sin 2x}{1 + \cos^2 2x} dx$$

$$\Rightarrow 2I = \frac{\pi}{4} \int_{-1}^1 \frac{dt}{1+t^2}, \quad t = \cos 2x$$

$$\Rightarrow I = \frac{\pi}{8} \cdot \left(\frac{\pi}{4} - \left(-\frac{\pi}{4}\right)\right) = \frac{\pi^2}{16}$$

3. Consider the terms 8, 21, 34, 47, ..., 320. The variance of the given data set is

- (1) 8788 (2) 8614
(3) 720 (4) 9402

Answer (1)

Sol. $\mu = \text{Mean} = \frac{8 + 21 + \dots + 320}{25} = \frac{25(8 + 320)}{2 \cdot 25} = 164$

$$\text{Variance} = \frac{8^2 + 21^2 + \dots + 320^2}{25} - (164)^2 = 8788$$

4. Let $M\left(\frac{1}{2}, 1\right)$ be the mid-point of a chord to the

Ellipse $\frac{x^2}{2} + \frac{y^2}{4} = 1$, then the length of chord is

- (1) $\frac{2}{3}\sqrt{5}$ (2) $\frac{\sqrt{5}}{3}$
(3) $2\sqrt{\frac{5}{3}}$ (4) $\frac{\sqrt{5}}{2}$

Answer (3)

Sol. $\frac{x^2}{2} + \frac{y^2}{4} = 1$

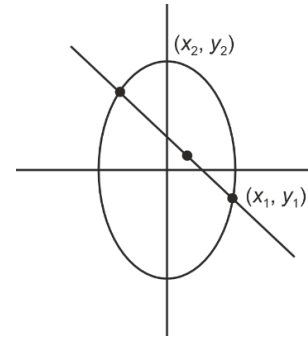

The equation of chord bisected at $\left(\frac{1}{2}, 1\right)$ will be $T = S_1$.

$$\Rightarrow \frac{x}{2} \left(\frac{1}{2}\right) + \frac{y}{4} (1) - 1 = \frac{\left(\frac{1}{2}\right)^2}{2} + \frac{1^2}{4} - 1$$

$$\Rightarrow \frac{x}{4} + \frac{y}{4} = \frac{1}{8} + \frac{1}{4}$$

$$\Rightarrow x + y = \frac{3}{2} \Rightarrow x_1 + y_1 = \frac{3}{2}$$

$$x_2 + y_2 = \frac{3}{2}$$

$$\Rightarrow (x_1 - x_2) + (y_1 - y_2) = 0$$

$$\Rightarrow (x_1 - x_2)^2 = (y_1 - y_2)^2$$

$$2x^2 + y^2 = 4$$

$$2x^2 + \left(\frac{3}{2} - x\right)^2 = 4$$

$$3x^2 - 3x + \frac{9}{4} - 4 = 0$$

$$\Rightarrow 3x^2 - 3x - \frac{7}{4} = 0$$

$$x_1 + x_2 = 1$$

$$x_1 \cdot x_2 = \frac{-7}{12}$$

$$(x_1 - x_2)^2 = (x_1 + x_2)^2 - 4x_1 x_2$$

$$= 1 + \frac{28}{12} = \frac{10}{3}$$

$$\Rightarrow \text{Length of chord} = \sqrt{\frac{10}{3} + \frac{10}{3}} = \sqrt{\frac{20}{3}} = 2\sqrt{\frac{5}{3}}$$

Delivering Champions Consistently

JEE (Advanced) 2024						JEE (Main) 2024		
 AIR 25 Rishi Shekher Shukla 2-Year Classroom	 AIR 67 Krishna Sai Shishir 2-Year Classroom	 AIR 78 Abhishek Jain 2-Year Classroom	 AIR 93 Hardik Aggarwal 2-Year Classroom	 AIR 95 Ujjwal Singh 2-Year Classroom	 AIR 98 Rishit Aggarwal 2-Year Classroom	 100 PERCENTILE Sanyal Jais 2-Year Classroom	 AIR 15 M Sai Divya Tuja Reddy 2-Year Classroom	 AIR 19 Rishi Shekher Shukla 2-Year Classroom

5. If the square of the shortest distance between the lines $\frac{x-2}{1} = \frac{y-1}{2} = \frac{z+3}{-3}$ and $\frac{x+1}{2} = \frac{y+3}{4}$ is $\frac{z+5}{-5}$ is $\frac{m}{n}$ (where m, n are coprime number)

then $m + n$ equals to

- (1) 6 (2) 9
(3) 21 (4) 14

Answer (2)

Sol. $\frac{x-2}{1} = \frac{y-1}{2} = \frac{z+3}{-3}$

$\frac{x+1}{2} = \frac{y+3}{4} = \frac{z+5}{-5}$

$a_1 = (2, 1, -3)$

$a_2 = (-1, -3, -5)$

$\vec{b}_1 \times \vec{b}_2 = \begin{vmatrix} \hat{i} & \hat{j} & \hat{k} \\ 1 & 2 & -3 \\ 2 & 4 & -5 \end{vmatrix}$

$2\hat{i} - \hat{j}$

$(SD)^2 = \left| \frac{(a_2 - a_1) \cdot (\vec{b}_1 \times \vec{b}_2)}{|\vec{b}_1 \times \vec{b}_2|} \right|^2$

$= \left| \frac{(3\hat{i} + 4\hat{j} + 2\hat{k}) \cdot (2\hat{i} - \hat{j})}{\sqrt{4+1}} \right|^2$

$= \left(\frac{2}{\sqrt{5}} \right)^2 = \frac{4}{5}$

$m + n = 9$

6. A rod of length 8 units having two end points always lie on $x - y + 2 = 0$ and $x + y + 2 = 0$. A point P divide this line in ratio 2 : 1. Then locus of P is

- (1) $9x^2 + 9y^2 + 36x - 28 = 0$
(2) $8x^2 + 8y^2 + 36x + 27 = 0$
(3) $9x^2 + 9y^2 - 36x + 28 = 0$
(4) $8x^2 + 8y^2 - 36x - 27 = 0$

Answer (1)

Sol. $x - y + z = 0$

$x + y + z = 0$

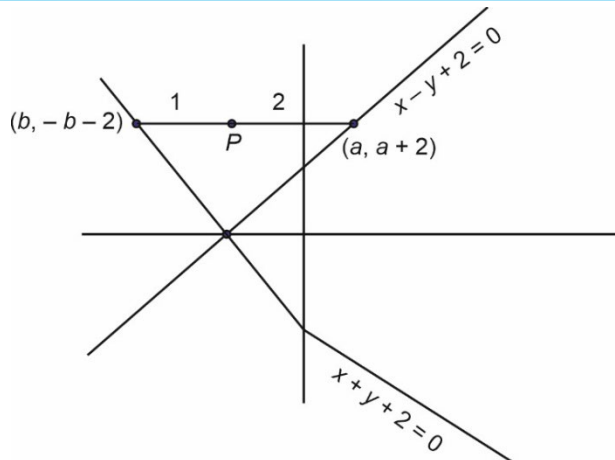

$PQ = 8$

$\Rightarrow (a - b)^2 + (a + 2 + b + 2)^2 = 64$

$(a - b)^2 + (a + b + 4)^2 = 64$

$2a^2 + 2b^2 - 2ab + 16 + 2(ab + 4b + 4a) = 64$

$\Rightarrow 2a^2 + 2b^2 + 8a + 8b = 48$

$\Rightarrow a^2 + b^2 + 4a + 4b - 24 = 0 = (a + 2)^2 + (b + 2)^2 = 32$

$h = \frac{2b + 1(a)}{3}, K = \frac{2(-2 - b) + 1(a + 2)}{3}$

$3h = 2b + a, 3K = a - 2 - 2b \rightarrow$ Solve for a and b .

$a = \frac{3h + 3K + 2}{2}, b = \frac{3h - 3K - 2}{4}$

$(a + 2) = \left(\frac{3h + 3K + 6}{2} \right), b + 2 = \left(\frac{3h - 3K + 6}{2} \right)$

$\Rightarrow \left(\frac{3h + 3K + 6}{2} \right)^2 + \left(\frac{3h - 3K + 6}{2} \right)^2 = 32$

$9(x + y + z)^2 + 9(x - y + z)^2 = 128$

$18[x^2 + y^2 + 4x + 4] = 128 \Rightarrow x^2 + y^2 + 4x - \frac{28}{9} = 0$

7. Evaluate

$\lim_{x \rightarrow \infty} \left(\frac{2x^7 + 3x - 5}{3x^7 + 5x - 2} \right) \frac{(3x - 1)^2}{(\sqrt{3x + 2})^x}$

(1) $\frac{2}{3\sqrt{e}}$ (2) $\frac{3}{\sqrt{e}}$

(3) $\frac{2}{5\sqrt{e}}$ (4) $\frac{2}{\sqrt{e}}$

Answer (1)

Delivering Champions Consistently

Aakash
Medical | IIT-JEE | Foundations

JEE (Advanced) 2024

AIR 25 Rishi Shekher Shukla 2 Year Classroom	AIR 67 Krishna Sai Shishir 2 Year Classroom	AIR 78 Abhishek Jain 2 Year Classroom	AIR 93 Hardik Aggarwal 2 Year Classroom	AIR 95 Ujjwal Singh 2 Year Classroom	AIR 98 Rishit Aggarwal 2 Year Classroom
---	--	--	--	---	--

JEE (Main) 2024

Karnataka Topper 100 PERCENTILE AIR 1 Sarvi Jain 2 Year Classroom	Telangana Topper 100 PERCENTILE AIR 15 M Sai Divya Tuja Reddy 2 Year Classroom	Telangana Topper 100 PERCENTILE AIR 19 Rishi Shekher Shukla 2 Year Classroom
--	---	---

Sol. $\lim_{x \rightarrow \infty} \frac{\left[\frac{2x^7 + 3x - 5}{3x^7 + 5x - 2} \right]^{\frac{x}{2}}}{\left(\frac{(3x-1)^2}{(\sqrt{3x+2})^x} \right)^{\frac{x}{2}}}$

$\lim_{x \rightarrow \infty} M = \lim_{x \rightarrow \infty} \frac{2 + \frac{3}{x^6} - \frac{5}{x^7}}{3 + \frac{5}{x^6} - \frac{2}{x^7}} = \frac{2}{3}$

$\lim_{x \rightarrow \infty} N = \lim_{x \rightarrow \infty} \left(\frac{3x-1}{3x+2} \right)^{\frac{x}{2}} = (1^\infty \text{ form})$

$= e^L$

$L = \lim_{x \rightarrow \infty} \left(\frac{3x-1}{3x+2} - 1 \right) \frac{x}{2}$

$= \lim_{x \rightarrow \infty} -\frac{3x}{2(3x+2)} = \lim_{x \rightarrow \infty} -\frac{3}{2\left(3 + \frac{2}{x}\right)} = -\frac{3}{6} = -\frac{1}{2}$

$\therefore \lim_{x \rightarrow \infty} N = e^{-\frac{1}{2}}$

$\therefore \lim_{x \rightarrow \infty} MN = \frac{2}{3} e^{-\frac{1}{2}}$

8. Let S be the region consisting of points (x, y) such that $-1 \leq x \leq 1$ and $0 \leq y \leq a + e^{|x|} - e^{-|x|}$. If area of bounded region is $\frac{2(e^2 + 8e + 1)}{e}$ square units, then a is equal to

- (1) 8
- (2) 10
- (3) 7
- (4) 5

Answer (2)

Sol. $0 \leq y \leq a + e^{|x|} - e^{-|x|}$

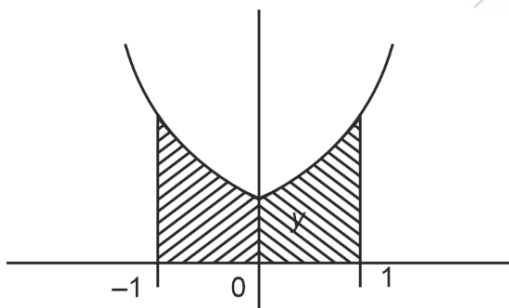

Area = $2 \int_0^1 (a + e^{|x|} - e^{-|x|}) dx$

$= 2 \int_0^1 (a + e^x - e^{-x}) dx$

$= 2(ax + e^x + e^{-x}) \Big|_0^1$

$= 2(a + e + e^{-1}) - 2(e^0 + e^{-0})$

$= 2\left(a + e + \frac{1}{e}\right) - 2(2)$

$= 2e + \frac{2}{e} + 2a - 4 = 2\left(e + \frac{1}{e} + (a - 2)\right)$

$= \frac{2(e^2 + (a - 2)(e + 1))}{e}$

Comparing, $a - 2 = 8 \Rightarrow a = 10$

9. If z is a complex number such that $|z| = 1$ and $\left| \frac{z}{\bar{z}} + \frac{\bar{z}}{z} \right| = 1$, then the number of complex number z is

- (1) 8
- (2) 4
- (3) 2
- (4) Zero

Answer (1)

Sol. $\left| \frac{z}{\bar{z}} + \frac{\bar{z}}{z} \right| = 1$

$\Rightarrow |z^2 + (\bar{z})| = 1$

$Z = x + iy$

$\Rightarrow |Z^2 + (\bar{Z})|^2 = |2(x^2 - y^2)|^2$

$\Rightarrow x^2 - y^2 = \pm \frac{1}{2}$

and $x^2 + y^2 = 1$

$x^2 - y^2 = \frac{1}{2}$ and $x^2 - y^2 = 1$

Delivering Champions Consistently

JEE (Advanced) 2024

- AIR 25**
 Rishi Shekher Shukla
 2-Year Classroom
- AIR 67**
 Krishna Sat Shishir
 2-Year Classroom
- AIR 78**
 Abhishek Jain
 2-Year Classroom
- AIR 93**
 Hardik Aggarwal
 2-Year Classroom
- AIR 95**
 Ujjwal Singh
 2-Year Classroom
- AIR 98**
 Rishit Aggarwal
 2-Year Classroom

JEE (Main) 2024

- 100 PERCENTILE**
 Sarvi Jais
 2-Year Classroom
- 100 PERCENTILE**
 M Sai Divya Tuja Reddy
 2-Year Classroom
- 100 PERCENTILE**
 Rishi Shekher Shukla
 2-Year Classroom

Sol. $\Rightarrow S_{11} = \frac{11}{2}(2a + (11-1)d) = 88$

$\Rightarrow (a + 5d) = 8$

$a = 8 - 5\left(\frac{3}{2}\right) = \frac{1}{2}$

$T_{10} = a + 9d = \frac{1}{2} + 9\left(\frac{3}{2}\right) = \frac{1+27}{2} = 14$

$T_{11} = a + 10d = \frac{1}{2} + 10\left(\frac{3}{2}\right) = \frac{31}{2}$

\Rightarrow Sum of roots $= 14 + \frac{31}{2} = \frac{P}{3}$

Product of roots $= (14)\left(\frac{31}{2}\right) = \frac{q}{3}$

$\frac{p}{3} = \frac{59}{2}, q = (7.31) \cdot 3$

$P = \frac{59 \times 3}{2}, q = 651$

$\Rightarrow q - 2p = 651 - 59 \times 3 = 474$

- 13.
- 14.
- 15.
- 16.
- 17.
- 18.
- 19.
- 20.

SECTION - B

Numerical Value Type Questions: This section contains 5 Numerical based questions. The answer to each question should be rounded-off to the nearest integer.

21. There are 5 boys and 4 girls. The sum of number of ways in which they can be seated such that all boys sit together and number of ways such that no boys sit together is equal to

Answer (17280)

Sol. All boys sit together

$B_1 B_2 B_3 B_4 B_5 \quad G_1 G_2 G_3 G_4$

$= 5! \cdot 5!$

no boys sit together

$\uparrow G_1 \uparrow G_2 \uparrow G_3 \uparrow G_4 \uparrow$

$4! \cdot 5!$

$\therefore \text{sum} = 5! \cdot 5! + 5! \cdot 4!$

$= 5! (4! + 5!)$

$= 5! \cdot 4! (1 + 5) = 6 \cdot 4! \cdot 5! = 17280$

22. Let $f(x) = 6 + 16\cos\left(\frac{\pi}{3} - x\right)\cos\left(\frac{\pi}{3} + x\right)\cos x \sin 3x$

$\cos 6x$ if range of $f(x)$ is $[\alpha, \beta]$

then distance of (α, β) from $3x + 4y + 12 = 0$

Answer (11)

Sol. $f(x) = 6 + 16 \times \frac{1}{4} \cos 3x \sin 3x \cos 6x$

$= 6 + 2\sin 6x \cos 6x$

$= 6 + \sin 12x$

$R_{f(x)} \in [5, 7]$

Now distance $= \left| \frac{15 + 28 + 12}{\sqrt{3^2 + 4^2}} \right| = \frac{55}{5} = 11$

23. $A = \{(x, y) \mid |x + y| \geq 3\}$;

$B = \{(x, y) \mid |x| + |y| \leq 3\}$

Let $C = A \cap B$. Find the sum of $(x, y) \forall x, y \in C$.

Answer (0)

Sol. $|x| + |y| \leq 3$

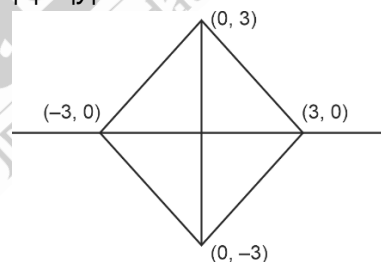

$|x + y| \geq 3$

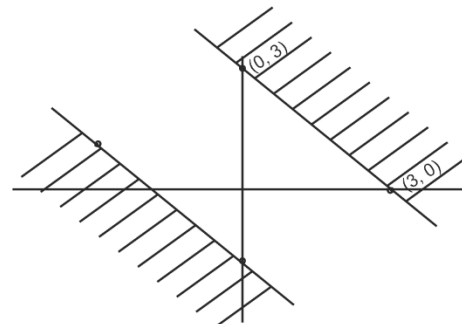

Delivering Champions Consistently

JEE (Advanced) 2024

- AIR 25
Rishi Shekher Shukla
2-Year Classroom
- AIR 67
Krishna Sai Shishir
2-Year Classroom
- AIR 78
Abhishek Jain
2-Year Classroom
- AIR 93
Hardik Aggarwal
2-Year Classroom
- AIR 95
Ujjwal Singh
2-Year Classroom
- AIR 98
Rishit Aggarwal
2-Year Classroom

JEE (Main) 2024

- Karnataka Topper
100 PERCENTILE RANK
AIR 1
Sarvi Jain
2-Year Classroom
- Telangana Topper
100 PERCENTILE RANK
AIR 15
M Sai Divya Tuja Reddy
2-Year Classroom
- Telangana Topper
100 PERCENTILE RANK
AIR 19
Rishi Shekher Shukla
2-Year Classroom

$A \geq B =$

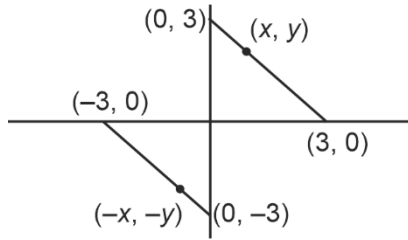

$\therefore \text{Sum} = 0$

24. If system of linear equations

$x + y + z = 6$

$x + 2y + 5z = 9$

$x + 5y + \lambda z = \mu$

has no solutions. Then value of λ equals to

Answer (17)

Sol. $\Delta = \begin{vmatrix} 1 & 1 & 1 \\ 1 & 2 & 5 \\ 1 & 5 & \lambda \end{vmatrix} = 0$

$\lambda - 17 = 0$

$\Rightarrow \lambda = 17$

For no solution $\Delta = 0$ at least one of $\Delta_1, \Delta_2, \Delta_3 \neq 0$

$\Delta_1 = \begin{vmatrix} 6 & 1 & 1 \\ 9 & 2 & 5 \\ \mu & 5 & 17 \end{vmatrix} \neq 0$

$\Rightarrow 3\mu - 54 \neq 0$

$\mu \neq 18$

\Rightarrow for $\mu \neq 18$ and $\lambda = 17$ given system of equations have no solution.

25. Let $\int x^3 \sin x dx = g(x) + C$, where $g(0) = 0$. If

$8 \left(g\left(\frac{\pi}{2}\right) + g'\left(\frac{\pi}{2}\right) \right) = \alpha\pi^3 + \beta\pi^2 + \gamma$, where α, β and γ are integers, then the value of $\alpha + \beta + \gamma$ is

Answer (55)

Sol. $I = \int x^3 \sin x dx = x^3(-\cos x) - \int 3x^2(-\cos x) dx$

$= -x^3 \cos x + 3 \left[x^2(\sin x) - \int 2x \sin x dx \right]$

$= -x^3 \cos x + 3x^2 \sin x - 6 \left[x(-\cos x) - \int (-\cos x) dx \right]$

$= -x^3 \cos x + 3x^2 \sin x + 6x \cos x - 6 \sin x + c$

$\because g(0) = 0 \Rightarrow g(x) = -x^3 \cos x + 3x^2 \sin x + 6x \cos x - 6 \sin x$

$= g\left(\frac{\pi}{2}\right) = \frac{3\pi^2}{4} - 6, \quad g'\left(\frac{\pi}{2}\right) = \left(\frac{\pi}{2}\right)^3 \sin\left(\frac{\pi}{2}\right) = \frac{\pi^3}{8}$

$\Rightarrow 8 \left[g\left(\frac{\pi}{2}\right) + g'\left(\frac{\pi}{2}\right) \right] = 6\pi^2 - 48 + \pi^3 = \pi^3 + 6\pi^2 - 48$

$\Rightarrow \alpha = 1, \beta = 6, \gamma = -48$

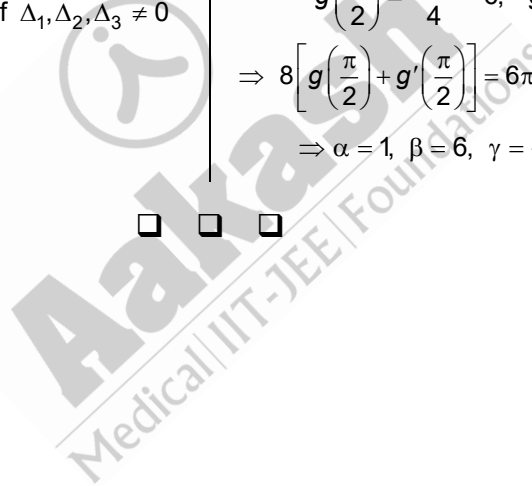

Delivering Champions Consistently

Aakash
Medical | IIT-JEE | Foundations

JEE (Advanced) 2024

AIR 25 Rishi Shekher Shukla 2 Year Classroom	AIR 67 Krishna Sai Shishir 2 Year Classroom	AIR 78 Abhishek Jain 2 Year Classroom	AIR 93 Hardik Aggarwal 2 Year Classroom	AIR 95 Ujjwal Singh 2 Year Classroom	AIR 98 Rishit Aggarwal 2 Year Classroom
---	--	--	--	---	--

JEE (Main) 2024

100 PERCENTILE AIR 1 Sarvi Jais 2 Year Classroom	100 PERCENTILE AIR 15 M Sai Divya Tuja Reddy 2 Year Classroom	100 PERCENTILE AIR 19 Rishi Shekher Shukla 2 Year Classroom
---	--	--